

1.1.2.4 Low - Medium Power Thermal Sensors - Apertures to 26mm

1.1.2.4.2 Standard OEM Smart Sensors

10mW to 150W

Features

- Sensors come with threaded holes for mounting to host system
- Compact
- Up to 150W
- Ø12 to Ø26mm apertures



Model	20C-BB-12-SH	L30C-SH	L30C-LP2-26-SH	100C-BB-18-SH	150C-SH / 150W-SH
Use	Compact	Larger aperture	High pulse energy and intermittent power	Slim profile	Compact higher power
Absorber Type	Broadband	Broadband	LP2	Broadband	Broadband
Spectral Range μm	0.19 - 11	0.19 - 20	0.25 - 2.2	0.19 - 11	0.19 - 20
Absorption	~88%	~88%	>94% from 0.25 to 1.1 μm	~88%	~88%
Aperture mm	Ø12	Ø26	Ø26	Ø18	Ø18
Power Mode					
Minimum power	10mW	300mW	300mW	60mW	60mW / 100mW
Maximum power free standing	4W continuous, 20W for 1.8min	10W continuous, 100W for 2min	10W continuous, 100W for 2min	4W	5W continuous, 150W for 1min
Maximum power heat sinked	20W	100W	100W	100W	60W cond. / 150W water
Power Scales	20W / 3W	100W / 10W	100W / 10W	100W / 30W / 3W	150W / 30W
Power Noise Level	0.2mW	15mW	15mW	3mW	3mW / 5mW
Maximum Average Power Density kW/cm ²	23 at 20W, 35 at 4W	14 at 100W, 28 at 10W	42 at 100W	30 at 4W, 14 at 100W	30 at 5W, 20 at 60W / 12 at 150W
Response Time with Meter (0-95%), typ. s	0.8	1.5	1.5	1.2	1.2
Calibration Uncertainty $\pm\%$	1.9	1.9	1.9	1.9	1.9
Power Accuracy $\pm\%$	3	3	3 ^(b)	3	3
Linearity with Power $\pm\%$	1	1.5	1.5	1	1
Energy Mode					
Energy Range	6mJ-10J	30mJ-100J	30mJ-2000J	NA	20mJ-100J / 50mJ-100J
Energy Scales	10J / 1J	100J / 30J / 3J / 300mJ	2kJ / 300J / 30J / 3J / 300mJ	NA	100J / 30J / 3J
Minimum Energy mJ	6	30	30	NA	20
Maximum Energy Density J/cm ²					
<100ns	0.3	0.3	0.1	0.3	0.3
0.5ms	5	5	50	5	5
2ms	10	10	130	10	10
10ms	30	30	400	30	30
>300ms	NA	NA	See below ^(c, d)	NA	NA
Cooling	Conduction	Conduction	Conduction	Conduction	Conduction / Water
Weight kg	0.2	0.3	0.3	0.2	0.3
Compliance	CE, UKCA, China RoHS	CE, UKCA, China RoHS	CE, UKCA, China RoHS	CE, UKCA, China RoHS	CE, UKCA, China RoHS
Version	V1			V1	
Part number	7Z07129	773434	7Z02775	7Z07126	7N77023^(a) / 771001

Note: (a) P/N 7N77023 replaces P/N 77023

Note: (b) Above 1.1 μm there is an additional calibration uncertainty of up to 2%

Note: (c) Long pulses (0.5 – 4s) can be used to measure power of high power lasers by measuring the energy of a short exposure. The StarBright, Juno, Juno+, Juno-RS and Centauri meters have a Pulsed Power mode where the user may specify the pulse width and get a reading directly in units of power for this short exposure energy measurement. See also page 107

Note: (d) Recommended exposure times and 1/e ² Gaussian beam diameters for very long pulses. Total energy for a series of measurements should not exceed 2kJ. Recommended time between shots 12s.	Laser Power W	Recommended Exposure s	Number of shots before cooling down	Min 1/e ² beam dia. mm
	100	4	20	9
	500	1	20	9
	1000	1	10	13
	2000	1	5	17
	4000	0.5	5	22

* For drawings please see page 65

20C-BB-12-SH

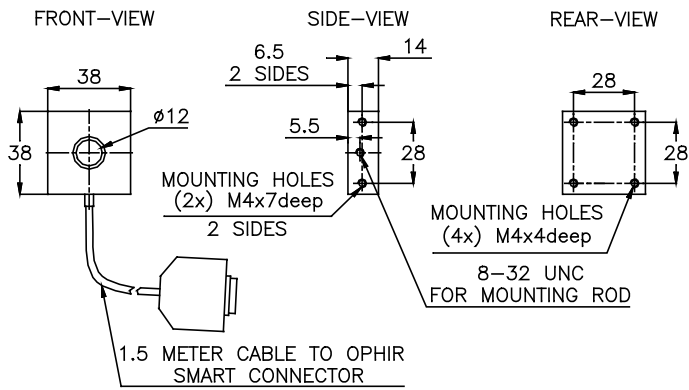

L30C-SH / L30C-LP2-26-SH

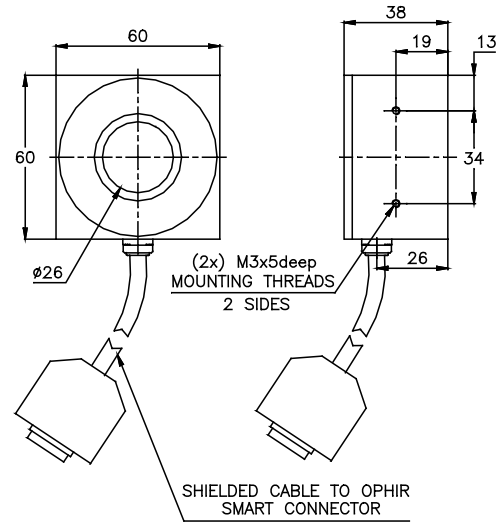

100C-BB-18-SH

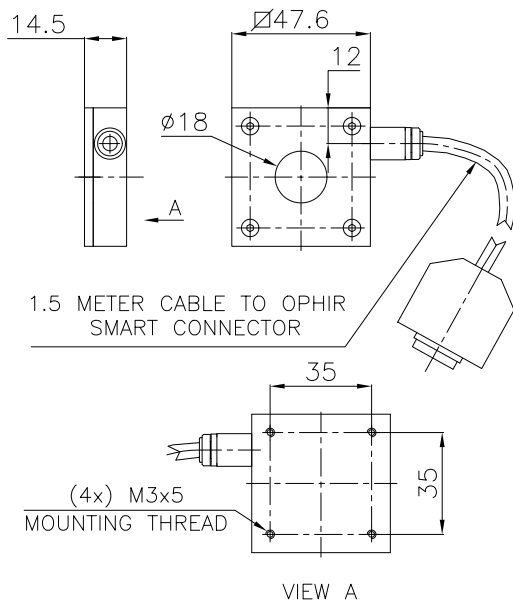

150C-SH

