

NO₂-D4 Nitrogen Dioxide Sensor – Miniature Size

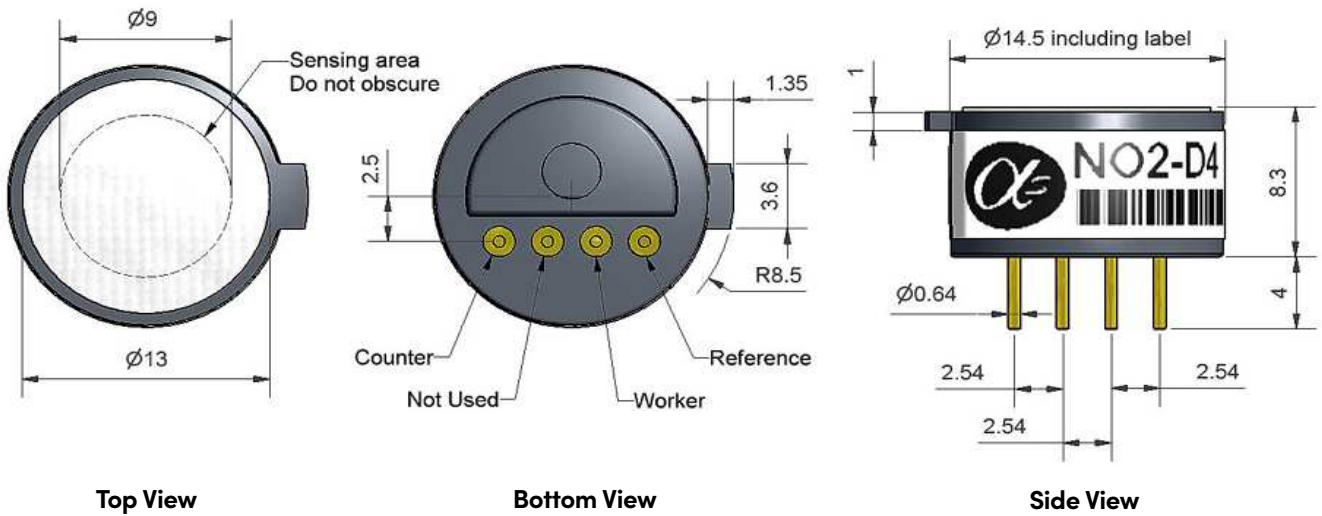

Dimensions are in millimetres (± 0.1 mm).

Performance	Sensitivity	nA/ppm in 10ppm NO ₂	-100 to -350
	Response time	t ₉₀ (s) from zero to 10ppm NO ₂	< 35
	Zero current	ppm equivalent in zero air	± 0.8
	Resolution	RMS noise (ppm equivalent)	0.1
	Range	ppm NO ₂ limit of performance warranty	20
	Linearity	ppm error at full scale, linear at zero and 10ppm NO ₂	0 to -0.6
	Overgas limit	maximum ppm for stable response to gas pulse	60
	Lifetime	Zero drift	ppm equivalent change/year in lab air
Sensitivity drift		% change/month in lab air, twice monthly test	nd
Operating life		months until 80% original signal (24 month warranted)	> 18
Environmental	Sensitivity @ -20°C	% (output @ -20°C/output @ 20°C) @ 10ppm	75 to 95
	Sensitivity @ 50°C	% (output @ 50°C/output @ 20°C) @ 10ppm	90 to 105
	Zero @ -20°C	ppm equivalent change from 20°C	< ± 0.6
	Zero @ 50°C	ppm equivalent change from 20°C	< ± 1.5
Cross-sensitivity	H ₂ S sensitivity	% measured gas @ 20ppm	H ₂ S < -200
	Cl ₂ sensitivity	% measured gas @ 10ppm	Cl ₂ < 120
	NO sensitivity	% measured gas @ 50ppm	NO < 0.5
	SO ₂ sensitivity	% measured gas @ 20ppm	SO ₂ < -3
	CO sensitivity	% measured gas @ 400ppm	CO < 0.1
	H ₂ sensitivity	% measured gas @ 400ppm	H ₂ < 0.1
	C ₂ H ₄ sensitivity	% measured gas @ 400ppm	C ₂ H ₄ < 0.1
	NH ₃ sensitivity	% measured gas @ 20ppm	NH ₃ < 0.1
	CO ₂ sensitivity	% measured gas @ 10%	CO ₂ < 0.1
	O ₃ sensitivity	% measured gas @ 200ppb	O ₃ < 70
Key Specifications	Temperature range	°C	-20 to 50
	Pressure range	kPa	80 to 120
	Humidity range	% rh (see note below)	15 to 90
	Storage period	months @ 3 to 20°C (stored in sealed pot)	6
	Load resistor	Ω (for optimum performance)	33
	Weight	g	< 2

Figure 1 Sensitivity Temperature Dependence

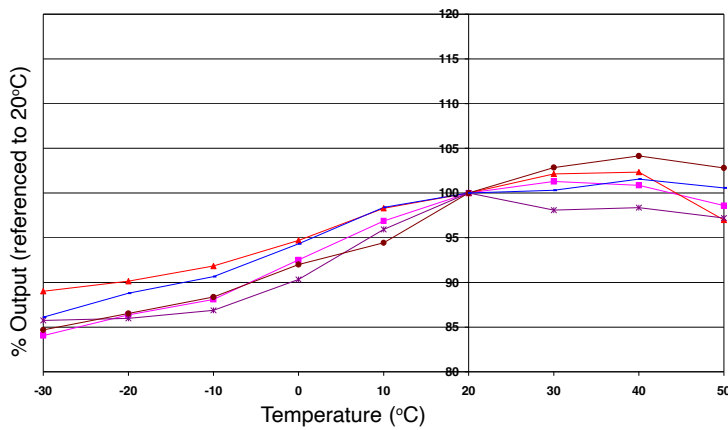

Figure 1 shows the variation in sensitivity caused by changes in temperature.

This data is taken from a typical batch of NO₂-D4 sensors. Good repeatability means accurate temperature compensation.

Figure 2 Zero Temperature Dependence

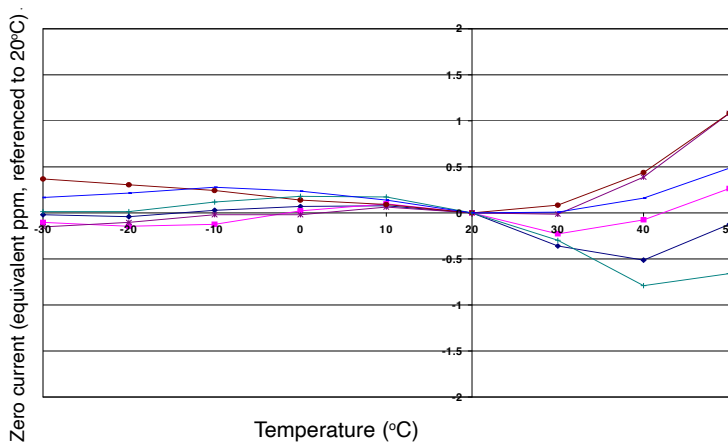
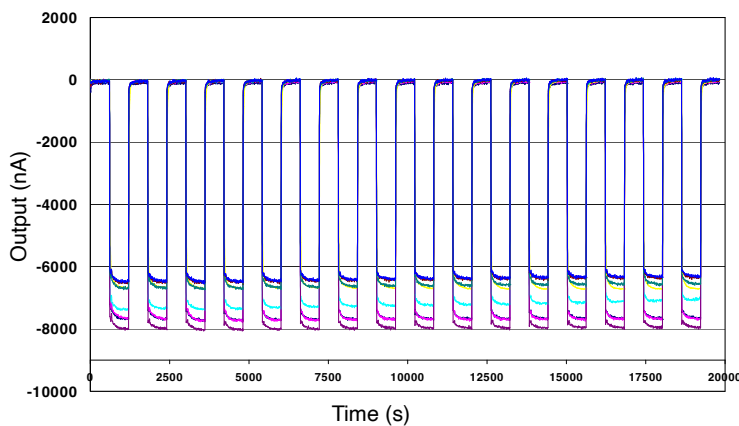

Figure 2 shows the variation in zero output caused by changes in temperature, expressed as ppm gas equivalent, referenced to zero at 20°C.

This data is taken from a typical batch of sensors.

Figure 3 Repeated gassing with 20ppm NO₂



This hysteresis graph shows stable response when gassed repeatedly with 20ppm NO₂.

Note: Above 85% rh and 40°C a maximum continuous exposure period of 10 days is warranted. Where such exposure occurs the sensor will recover normal electrolyte volumes when allowed to rest at lower %rh and temperature levels for several days.

At the end of the product's life, do not dispose of any electronic sensor, component or instrument in the domestic waste, but contact the instrument manufacturer, Alphasense or its distributor for disposal instructions. NOTE: all sensors are tested at ambient environmental conditions unless otherwise stated. As applications of use are outside our control, the information provided is given without legal responsibility. Customers should test under their own conditions, to ensure that the sensors are suitable for their own requirements.

In the interest of continued product improvement, we reserve the right to change design features and specifications without prior notification. The data contained in this document is for guidance only. Alphasense Ltd accepts no liability for any consequential losses, injury or damage resulting from the use of this document or the information contained within. (©ALPHASENSE LTD) Doc. Ref. NO2-D4/SEP22