

## PRHT-A1 and RHT-A1 Pressure and Humidity Sensors

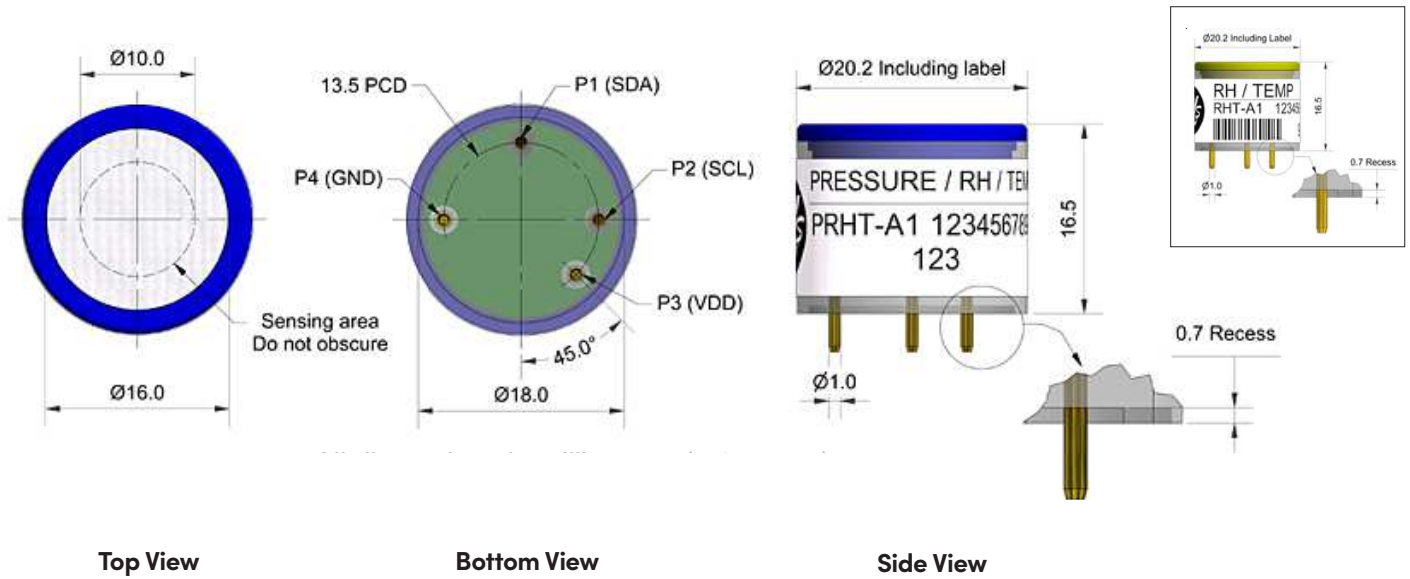

**Top View**

**Bottom View**

**Side View**

Dimensions are in millimetres ( $\pm 0.15$  mm).

When measuring air quality, gas, particle and VOC sensors must be compensated correctly for temperature and relative humidity; PID and NDIR sensors also require pressure correction.

These sensors provide a simple digital solution for those environmental measurements and can be located next to the gas sensors - an important solution to an air quality problem.

The RHT-A1 measures both temperature and relative humidity; the PRHT-A1 measures temperature and relative humidity, plus barometric (absolute) pressure. Both sensors provide a digital, corrected output via an I2C interface, direct to your microprocessor.

The PRHT-A1 and RHT-A1 solve three requirements when measuring air quality:

1. Temperature and humidity measurement sensors must be kept away from heat sources
2. Temperature and relative humidity sensors should be next to the sensors to be compensated
3. The humidity sensor should respond as fast as the gas sensors

Performance	Temperature error	°C	$\pm 0.2$
	RH error	%RH	$\pm 2$
	Pressure error max	hPa/mbar	$\pm 4$
	Pressure error typical	hPa/mbar (constant T)	$\pm 0.5$
	Pressure error typical	hPa/mbar (-10°C to +50°C)	$\pm 1$

Environmental	Temperature range	°C	-40 to +80
	Humidity range	%RH	0 to 95
	Weight	g	6

Electrical	Voltage range PRHT-A1	VDC	2.3 to 3.6V
	Voltage range RHT-A1	VDC (typ)	3.3
		VDC (max)	2.3 to 5.5
	Current measuring	$\mu$ A	< 850
	Current idle mode PRHT-A1	$\mu$ A	4
	Current idle mode RHT-A1	$\mu$ A	2

**I2C interface** SDA/ SDL and SCL pins (1mm dia)

At the end of the product's life, do not dispose of any electronic sensor, component or instrument in the domestic waste, but contact the instrument manufacturer, Alphasense or its distributor for disposal instructions.

In the interest of continued product improvement, we reserve the right to change design features and specifications without prior notification. The data contained in this document is for guidance only. Alphasense Ltd accepts no liability for any consequential losses, injury or damage resulting from the use of this document or the information contained within. (©ALPHASENSE LTD) Doc. Ref. PRHT-RHT/SEP22