



**VAISALA**

# USER'S GUIDE

## Vaisala HUMICAP® Moisture and Temperature Transmitter for Oil MMT330



## PUBLISHED BY

Vaisala Oyj

Street address: Vanha Nurmijärventie 21, FI-01670 Vantaa, Finland

Mailing address: P.O. Box 26, FI-00421 Helsinki, Finland

Phone: +358 9 8949 1

Fax: +358 9 8949 2227

Visit our Internet pages at [www.vaisala.com](http://www.vaisala.com).

© Vaisala 2015

No part of this manual may be reproduced, published or publicly displayed in any form or by any means, electronic or mechanical (including photocopying), nor may its contents be modified, translated, adapted, sold or disclosed to a third party without prior written permission of the copyright holder. Translated manuals and translated portions of multilingual documents are based on the original English versions. In ambiguous cases, the English versions are applicable, not the translations.

The contents of this manual are subject to change without prior notice.

This manual does not create any legally binding obligations for Vaisala towards customers or end users. All legally binding obligations and agreements are included exclusively in the applicable supply contract or the General Conditions of Sale and General Conditions of Service of Vaisala.

---

# Table of Contents

## CHAPTER 1

<b>GENERAL INFORMATION</b> .....	<b>11</b>
<b>About This Manual</b> .....	<b>11</b>
Contents of This Manual .....	11
Version Information .....	12
Documentation Conventions .....	12
<b>Safety</b> .....	<b>13</b>
<b>ESD Protection</b> .....	<b>13</b>
<b>Recycling</b> .....	<b>14</b>
<b>Regulatory Compliances</b> .....	<b>14</b>
EU Declaration of Conformity.....	14
DNV Type Approval .....	15
Transmitters with LAN or WLAN Interface .....	16
Transmitters with WLAN Interface .....	16
<b>Patent Notice</b> .....	<b>17</b>
<b>Trademarks</b> .....	<b>17</b>
<b>Software License</b> .....	<b>17</b>
<b>Warranty</b> .....	<b>17</b>

## CHAPTER 2

<b>PRODUCT OVERVIEW</b> .....	<b>19</b>
<b>Introduction to MMT330</b> .....	<b>19</b>
Basic Features and Options.....	20
Structure of the Transmitter .....	20
Probe Options .....	22
Typical Applications .....	23
Methods Used for Measuring Moisture in Oil.....	23
Lubrication Oil in Paper Machines .....	23
Transformer Oil .....	24

## CHAPTER 3

<b>INSTALLATION</b> .....	<b>27</b>
<b>Mounting the Housing</b> .....	<b>27</b>
Standard Mounting.....	27
Wall Mounting with Wall Mounting Kit.....	28
Mounting with DIN Rail Installation Kit .....	29
Pole Installation with Installation Kit for Pole or Pipeline ....	29
Mounting Rain Shield with Installation Kit .....	31
Panel Mounting Frame .....	32
<b>Wiring</b> .....	<b>33</b>
Cable Bushings .....	33
Grounding the Cables .....	34
Grounding the Transmitter Housing.....	35
Signal and Power Supply Wiring.....	36

Connections to a 24 VAC Power Supply.....	38
MMT332 for High-Pressure Applications.....	39
MMT337 Small Pressure-Tight Probe .....	39
MMT337 Probe with Swagelok Connector for Tight-place Installations.....	40
MMT338 for Pressurized Pipelines .....	42
Tightening the Clasp Nut.....	43
Ball Valve Installation Kit for MMT338.....	44
Sampling Cell for MMT338.....	47
<b>Optional Modules.....</b>	<b>48</b>
Power Supply Module.....	48
Installation .....	49
Warnings .....	50
Galvanic Isolation for Power Supply.....	53
Third Analog Output .....	53
Installation and Wiring .....	54
Relays.....	55
Installation and Wiring.....	55
Selecting the Activation State of the Relay .....	55
RS-422/485 Interface .....	56
Installation and Wiring.....	57
LAN Interface.....	61
WLAN Interface .....	62
Attaching the WLAN Antenna.....	63
Data Logger Module .....	63
8-Pin Connector.....	65
CHAPTER 4	
<b>OPERATION.....</b>	<b>67</b>
<b>Getting Started.....</b>	<b>67</b>
<b>Display/Keypad (Optional).....</b>	<b>67</b>
Basic Display .....	67
Graphic History.....	68
Menus and Navigation.....	70
Changing the Language .....	71
Rounding Setting .....	71
Display Backlight Setting.....	71
Display Contrast Setting.....	72
Using Display/Keypad .....	72
Using Serial Line .....	72
Keypad Lock (Keyguard).....	72
Menu PIN Lock.....	73
Factory Settings .....	73
Display Alarms.....	74
Configuring a Display Alarm.....	75
Using Serial Line .....	76
<b>MI70 Link Program for Data Handling .....</b>	<b>78</b>
<b>Serial Line Communication .....</b>	<b>79</b>
User Port Connection .....	80
User Port Operating Modes.....	80
Service Port Connection.....	81
Connection Cables .....	81
Installing the Driver for the USB Cable .....	81

---

Using the Service Port .....	82
<b>LAN Communication.....</b>	<b>82</b>
IP Configuration .....	83
Using Display/Keypad .....	84
Using Serial Line .....	85
Wireless LAN Configuration .....	86
Using Display/Keypad .....	87
Using Serial Line .....	88
Communication Protocol .....	89
Web Configuration for LAN and WLAN.....	89
Terminal Program Settings .....	90
Opening a Serial/USB connection .....	90
Opening a Telnet session (LAN/WLAN) .....	92
List of Serial Commands .....	93
Getting Measurement Message from Serial Line.....	95
Starting Continuous Outputting .....	95
Stopping Continuous Outputting .....	96
Outputting Reading Once .....	96
Assign an Alias for the SEND Command .....	96
Outputting Reading Once From All Transmitters.....	97
<b>Communicating with a Transmitter in POLL Mode.....</b>	<b>97</b>
OPEN .....	97
CLOSE .....	97
Formatting Serial Line Message .....	98
FTIME and FDATE.....	98
<b>General Settings.....</b>	<b>99</b>
Changing Quantities and Units .....	99
Using Display/Keypad .....	99
Using Serial Line .....	100
FORM.....	100
UNIT .....	101
Date and Time.....	102
Using Display/Keypad .....	102
Using Serial Line .....	102
Data Filtering .....	103
Using Display/Keypad .....	103
Using Serial Line .....	103
Device Information .....	104
? .....	104
LIGHT.....	105
HELP .....	106
ERRS .....	106
MODS .....	106
VERS .....	106
Resetting Transmitter by Using Serial Line.....	107
RESET .....	107
Locking Menu/Keypad Using Serial Line .....	107
LOCK .....	107
<b>Serial Output Settings.....</b>	<b>108</b>
Using Display/Keypad .....	108
Using Serial Line .....	109
SERI.....	109
SMODE .....	109
ADDR .....	110

INTV .....	110
SDELAY .....	111
ECHO .....	111
<b>Data Recording .....</b>	<b>111</b>
Selecting Data Recording Quantities .....	112
DSEL .....	112
View Recorded Data.....	112
DIR .....	113
PLAY .....	114
Deleting the Recorded Files .....	115
UNDELETE .....	115
<b>Analog Output Settings .....</b>	<b>116</b>
Changing Output Mode and Range.....	116
Analog Output Quantities .....	117
AMODE/ASEL .....	118
Analog Output Tests.....	119
ITEST .....	119
Analog Output Fault Indication Setting.....	120
AERR.....	120
Extend Analog Output Range.....	121
<b>Operation of Relays.....</b>	<b>121</b>
Quantity for Relay Output.....	121
Relay Setpoints .....	121
Hysteresis .....	123
Relay Indicating Transmitter Error Status .....	123
Enabling/Disabling Relays.....	125
Setting Relay Outputs.....	125
RSEL .....	127
Testing Operation of Relays .....	129
RTEST.....	129

CHAPTER 5

<b>MODBUS .....</b>	<b>131</b>
<b>Overview of Modbus Protocol Support .....</b>	<b>131</b>
Taking Modbus into Use.....	132
<b>Enabling Serial Modbus.....</b>	<b>133</b>
Using Display/Keypad (Optional) .....	133
Using Serial Line .....	133
<b>Enabling Ethernet Modbus .....</b>	<b>134</b>
Using Display/Keypad (Optional) .....	134
Using Serial Line .....	136
<b>Diagnostic Modbus Counters.....</b>	<b>137</b>
Viewing Counters Using Display/Keypad .....	137
Viewing Counters Using Service Port .....	137
<b>Disabling Modbus.....</b>	<b>138</b>

CHAPTER 6

<b>PPM CONVERSION .....</b>	<b>139</b>
<b>MMT330 ppm Conversion for Transformer Oils .....</b>	<b>139</b>
<b>Conversion Model with Average Coefficients .....</b>	<b>139</b>
<b>Conversion Model with Oil-specific Coefficients .....</b>	<b>140</b>

---

<b>Setting Oil Coefficients Using Serial Line .....</b>	<b>140</b>
OIL.....	140
Using Display/Keypad .....	141
<b>Determination of Oil-Specific Coefficients .....</b>	<b>141</b>
CHAPTER 7	
<b>MAINTENANCE .....</b>	<b>143</b>
<b>Periodic Maintenance .....</b>	<b>143</b>
Cleaning .....	143
Changing the Probe Filter .....	143
<b>Changing the Sensor .....</b>	<b>144</b>
Error States .....	145
<b>Technical Support .....</b>	<b>147</b>
CHAPTER 8	
<b>CALIBRATION AND ADJUSTMENT .....</b>	<b>149</b>
<b>Cleaning the Sensor.....</b>	<b>150</b>
<b>Opening and Closing the Adjustment Mode .....</b>	<b>150</b>
<b>Relative Humidity Adjustment .....</b>	<b>151</b>
Using Push Buttons.....	151
Using Display/Keypad .....	152
Using Serial Line .....	153
CRH .....	153
<b>Relative Humidity Adjustment after Sensor Change.....</b>	<b>154</b>
Using Display/Keypad .....	154
Using Serial Line .....	154
FCRH .....	154
<b>Temperature Adjustment.....</b>	<b>155</b>
Using Display/Keypad .....	155
Using Serial Line .....	156
<b>Analog Output Adjustment.....</b>	<b>157</b>
Using Display/Keypad .....	157
Using Serial Line .....	157
ACAL .....	157
<b>Feeding Adjustment Information .....</b>	<b>158</b>
Using Display/Keypad .....	158
Using Serial Line .....	158
CTEXT .....	158
CDATE .....	158
CHAPTER 9	
<b>TECHNICAL DATA .....</b>	<b>159</b>
<b>Specifications .....</b>	<b>159</b>
Performance.....	159
Water Activity and Relative Saturation.....	159
Temperature.....	159
Operating Environment .....	160
Probe Specifications .....	160
MMT332 .....	160
MMT337 .....	160

MMT338 .....	160
Inputs and Outputs .....	161
Mechanics .....	161
Technical Specifications of Optional Modules.....	162
Power Supply Module .....	162
Analog Output Module.....	162
Relay Module .....	163
RS-485 Module .....	163
LAN Interface Module.....	163
WLAN Interface Module .....	163
Data Logger Module.....	164
<b>Spare Parts and Accessories .....</b>	<b>164</b>
<b>Dimensions (mm/inch) .....</b>	<b>166</b>
MMT332 .....	168
MMT337 .....	168
MMT337 with Swagelok Connector.....	169
MMT338 .....	169
APPENDIX A	
<b>MODBUS REFERENCE .....</b>	<b>171</b>
<b>Function Codes.....</b>	<b>171</b>
<b>Register Map .....</b>	<b>172</b>
Data Encoding .....	172
32-Bit Floating Point Format.....	172
16-Bit Integer Format .....	173
Measurement Data (Read-Only) .....	174
Status Registers (Read-Only) .....	174
Configuration Registers .....	174
<b>Exception Status Outputs.....</b>	<b>175</b>
<b>Diagnostic Sub-Functions .....</b>	<b>176</b>
<b>Device Identification Objects .....</b>	<b>177</b>
<b>Exception Responses .....</b>	<b>177</b>



---

## List of Figures

Figure 1	Transmitter Body .....	20
Figure 2	Inside the Transmitter.....	21
Figure 3	Probe Options .....	22
Figure 4	The Water Solubility of Transformer Oils versus Temperature	25
Figure 5	Standard Mounting Dimensions (in mm/inch) .....	27
Figure 6	Mounting with Wall Mounting Kit .....	28
Figure 7	Dimensions of the Plastic Mounting Plate (mm/inch).....	28
Figure 8	Mounting with DIN Rail Installation Kit .....	29
Figure 9	Vertical Pole .....	29
Figure 10	Horizontal Pole .....	30
Figure 11	Mounting with Metal Wall Mounting Plate .....	30
Figure 12	Dimensions of Metal Mounting Plate (mm/inch) .....	31
Figure 13	Mounting Rain Shield with Installation Kit .....	31
Figure 14	Panel Mounting Frame .....	32
Figure 15	Panel Mounting Dimensions (mm/inch) .....	33
Figure 16	Cable Bushings .....	33
Figure 17	Grounding the Screen of Electrical Cable .....	34
Figure 18	Screw Terminal Block on Motherboard .....	36
Figure 19	Connections to 24 VAC Power Supply.....	38
Figure 20	MMT332 Installation .....	39
Figure 21	MMT337 Probe with Swagelok Installation Kit .....	40
Figure 22	MMT337 Probe Installation to Pipeline with Swagelok Installation Kit .....	40
Figure 23	MMT338 Probe.....	42
Figure 24	Sealing of Fitting Body into Process .....	43
Figure 25	Tightening the Clasp Nut.....	43
Figure 26	Installing the MMT338 Probe through a Ball Valve Assembly .	45
Figure 27	Sampling Cell DMT242SC2 .....	47
Figure 28	Power Supply Module .....	48
Figure 29	Galvanic Isolation Module .....	53
Figure 30	Third Analog Output .....	53
Figure 31	Third Analog Output Selection .....	54
Figure 32	Relay Module .....	56
Figure 33	RS-422/485 Module .....	57
Figure 34	4-Wire RS-485 Bus .....	59
Figure 35	2-Wire RS-485 Bus .....	60
Figure 36	LAN Interface Module.....	61
Figure 37	WLAN Interface Module .....	62
Figure 38	Data Logger Module.....	64
Figure 39	Pinout of the Optional 8-Pin Connector.....	65
Figure 40	Basic Display .....	67
Figure 41	Graphical Display .....	68
Figure 42	Graphical Display with Data Logger .....	69
Figure 43	Main Menus .....	70
Figure 44	Display Alarm Active .....	74
Figure 45	Display Alarms .....	75
Figure 46	Modifying an Alarm Limit.....	75
Figure 47	Service Port Connector and User Port Terminal on Motherboard .....	79
Figure 48	Connection Example between PC Serial Port and User Port ..	80
Figure 49	Network Interface Menu .....	84
Figure 50	IP Configuration Menu.....	84

Figure 51	Wireless LAN Settings.....	87
Figure 52	Entering Network SSID.....	87
Figure 53	Selecting the Wireless Network Type.....	87
Figure 54	Web Configuration Interface for LAN.....	90
Figure 55	Opening a Serial Connection.....	91
Figure 56	Opening a Telnet Connection.....	92
Figure 57	Device Information on Display.....	104
Figure 58	Current/Voltage Switches of Output Modules .....	116
Figure 59	Measurement-Based Relay Output Modes .....	122
Figure 60	FAULT/ONLINE STATUS Relay Output Modes.....	124
Figure 61	Relay Indicators on Display .....	126
Figure 62	Serial Interface Settings .....	133
Figure 63	IP Configuration .....	135
Figure 64	Wireless LAN Settings.....	135
Figure 65	Communication Protocol .....	135
Figure 66	Modbus Counters .....	137
Figure 67	Changing the Sensor .....	144
Figure 68	Error Indicator and Error Message .....	145
Figure 69	Adjustment and Purge Buttons.....	150
Figure 70	Adjustment Menu.....	151
Figure 71	Selecting Point 1 Reference Type.....	152
Figure 72	Accuracy over Temperature Range.....	159
Figure 73	Transmitter Body Dimensions .....	166
Figure 74	WLAN Antenna Dimensions .....	167
Figure 75	MMT332 Probe Dimensions .....	168
Figure 76	MMT337 Probe Dimensions .....	168
Figure 77	MMT337 Probe with (Optional) Swagelok Connector, Dimensions .....	169
Figure 78	MMT338 Probe with Stainless Steel Filter (Oil Filter), Dimensions .....	169

---

## List of Tables

Table 1	Manual Revisions .....	12
Table 2	Application, Location Classes .....	15
Table 3	Quantities Measured by MMT330 .....	19
Table 4	Optional Quantities Measured by MMT330.....	19
Table 5	MMT338 Probe Dimensions.....	42
Table 6	Connecting the Twisted Pair Wires to the Screw Terminals ....	58
Table 7	4-Wire (Switch 3: On) .....	59
Table 8	2-Wire (Switch 3: Off) .....	60
Table 9	Observation Periods and Resolution.....	63
Table 10	Wiring of the Optional 8-Pin Connector.....	65
Table 11	Periods for Trend and Max/Min Calculations .....	68
Table 12	Graph Information Messages in Cursor Mode .....	69
Table 13	ALSEL Parameters.....	77
Table 14	Default Serial Communication Settings for the User Port.....	80
Table 15	Communication Settings for the Service Port .....	82
Table 16	IP Settings for the LAN and WLAN Interfaces .....	83
Table 17	Wireless LAN Settings.....	86
Table 18	Measurement Commands.....	93
Table 19	Formatting Commands.....	93
Table 20	Data Recording Commands .....	94
Table 21	Calibration and Adjustment Commands.....	94
Table 22	Setting and Testing the Analog Outputs .....	94
Table 23	Setting and Testing the Relays .....	94
Table 24	Other Commands .....	95
Table 25	FORM Command Modifiers.....	100
Table 26	Filtering Levels .....	103
Table 27	Selection of Output Modes .....	110
Table 28	Relay State Examples .....	125
Table 29	Supported Modbus Variants.....	131
Table 30	Error Messages .....	146
Table 31	Indicator Led Functions .....	151
Table 32	Standard Probe Cable Lengths and Approximate Transmitter Weight (in kg/lb) .....	162
Table 33	Spare Parts and Accessories .....	164
Table 34	Supported Function Codes.....	171
Table 35	MMT330 Modbus Register Blocks .....	172
Table 36	Measurement Data Registers.....	174
Table 37	Status Registers .....	174
Table 38	Configuration Parameter Registers .....	174
Table 39	Configuration Flag Registers.....	175
Table 40	MMT330 Exception Status Outputs .....	175
Table 41	MMT330 Modbus Diagnostics.....	176
Table 42	MMT330 Modbus Device Identification .....	177
Table 43	MMT330 Modbus Exception Responses .....	177

This page intentionally left blank.

# CHAPTER 1

## GENERAL INFORMATION

This chapter provides general notes for the manual and the product.

### About This Manual

This manual provides information for installing, operating, and maintaining Vaisala HUMICAP® Moisture and Temperature Transmitter for Oil MMT330.

### Contents of This Manual

This manual consists of the following chapters:

- Chapter 1, General Information, provides general notes for the manual and the product.
- Chapter 2, Product Overview, introduces the features, advantages, and the product nomenclature.
- Chapter 3, Installation, provides you with information that is intended to help you install the product.
- Chapter 4, Operation, contains information that is needed to operate this product.
- Chapter 5, Modbus, contains information that is needed when operating the transmitter using the Modbus protocol.
- Chapter 6, ppm Conversion, contains information on conversion models.
- Chapter 7, Maintenance, provides information that is needed in basic maintenance of the product.
- Chapter 8, Calibration and Adjustment, provides information that is needed in calibration and adjustment of the product.
- Chapter 9, Technical Data, provides the technical data of the product.
- Appendix A, Modbus Reference, describes the Modbus functions and data of the transmitter.

## Version Information

**Table 1** Manual Revisions

Manual Code	Description
M210733EN-H	September 2015. This manual. Relative saturation (%RS) added to the available quantities ( $a_w$ , T, ppm). High flow filter added to spare part list, HELP command output example corrected (PRES and XPRES removed from list of available commands). Pressure setting removed from Modbus configuration registers.
M210733EN-G	December 2013. Previous version. Added new command descriptions: ALSEL, AOVER, CON, DSEND, and MODS. Updated technical specification. Updated FILT command description. Various small corrections.
M210733EN-F	Previous version. Applicable from transmitter software version 5.10 onward. Added Modbus protocol. Updated serial line command descriptions. Updated storage temperature range.

## Documentation Conventions

Throughout the manual, important safety considerations are highlighted as follows:

**WARNING** Warning alerts you to a serious hazard. If you do not read and follow instructions very carefully at this point, there is a risk of injury or even death.

**CAUTION** Caution warns you of a potential hazard. If you do not read and follow instructions carefully at this point, the product could be damaged or important data could be lost.

**NOTE** Note highlights important information on using the product.

## Safety

The Vaisala HUMICAP® Moisture and Temperature Transmitter for Oil MMT330 delivered to you has been tested for safety and approved as shipped from the factory. Note the following precautions:

**WARNING** Ground the product, and verify outdoor installation grounding periodically to minimize shock hazard.

**CAUTION** Do not modify the unit. Improper modification can damage the product, lead to malfunction, or make the product noncompliant with applicable legislation.

## ESD Protection

Electrostatic Discharge (ESD) can cause immediate or latent damage to electronic circuits. Vaisala products are adequately protected against ESD for their intended use. However, it is possible to damage the product by delivering electrostatic discharges when touching, removing, or inserting any objects inside the equipment housing.

To make sure you are not delivering high static voltages yourself:

- Handle ESD sensitive components on a properly grounded and protected ESD workbench. When this is not possible, ground yourself to the equipment chassis before touching the boards. Ground yourself with a wrist strap and a resistive connection cord. When neither of the above is possible, touch a conductive part of the equipment chassis with your other hand before touching the boards.
- Always hold the boards by the edges and avoid touching the component contacts.

## Recycling



Recycle all applicable material.



Dispose of the unit according to statutory regulations. Do not dispose of with regular household refuse.

## Regulatory Compliances

### EU Declaration of Conformity

Vaisala HUMICAP® Moisture and Temperature Transmitter for Oil MMT330 is in conformity with the provisions of the following EU directives:

- Low Voltage Directive
- EMC-Directive
- ROHS Directive

Conformity is shown by compliance with the following standards:

- EN 60950-1
- EN 61326-1: Electrical equipment for measurement, control, and laboratory use – EMC requirements – for use in industrial locations.
- EN 550022: Information technology equipment – Radio disturbance characteristics – Limits and methods of measurement.





## DNV Type Approval

The Vaisala HUMICAP® Moisture and Temperature Transmitter for Oil MMT330 is found to comply with Det Norske Veritas' Rules for Classification of Ships, High Speed & Light Craft and Det Norske Veritas' Offshore standards.

Applicable tests carried out according to Standard for Certification No. 2.4, April 2006.

**Table 2 Application, Location Classes**

Type	MMT330
Temperature	B
Humidity	B
Vibration	A
EMC	B
Enclosure	B/IP65



TYPE APPROVED PRODUCT  
CERTIFICATE NO.: A-13529

## Transmitters with LAN or WLAN Interface

This equipment has been tested and found to comply with the limits for a Class B digital device, pursuant to Part 15 of the FCC Rules. These limits are designed to provide reasonable protection against harmful interference in a residential installation. Operation is subject to the following two conditions: (1) this device may not cause interference, and (2) this device must accept any interference, including interference that may cause undesired operation of the device.

This equipment generates, uses and can radiate radio frequency energy and, if not installed and used in accordance with the instructions, may cause harmful interference to radio communications. However, there is no guarantee that interference will not occur in a particular installation. If this equipment does cause harmful interference to radio or television reception, which can be determined by turning the equipment off and on, the user is encouraged to try to correct the interference by one or more of the following measures:

- Reorient or relocate the receiving antenna.
- Increase the separation between the equipment and receiver.
- Connect the equipment into an outlet on a circuit different from that to which the receiver is connected.
- Consult the dealer or an experienced radio/TV technician for help.

## Transmitters with WLAN Interface

This device has been designed to operate with a 2 dBi half-wave antenna. Antennas with a gain greater than 2 dBi are prohibited for use with this device. The antenna impedance is 50 ohms.

To reduce potential radio interference to other users, the antenna type and its gain should be so chosen that the equivalent isotropically radiated power (EIRP) is not more than that permitted for successful communication.

This Class [B] digital apparatus complies with Canadian ICES-003.

Cet appareil numérique de la classe [B] est conforme à la norme NMB-003 du Canada.

## Patent Notice

The Vaisala HUMICAP® Moisture and Temperature Transmitter for Oil MMT330 is protected by, for example, the following patents and their corresponding national rights:

Finnish patent 98861, French patent 6650303, German patent 69418174, Japanese patent 3585973, UK patent 0665303, and U.S. patent 5607564.

## Trademarks

HUMICAP® is a registered trademark of Vaisala Oyj.

All other trademarks are the property of their respective owners.

## Software License

This product contains software developed by Vaisala. Use of the software is governed by license terms and conditions included in the applicable supply contract or, in the absence of separate license terms and conditions, by the General License Conditions of Vaisala Group.

## Warranty

Visit our Internet pages for standard warranty terms and conditions:  
[www.vaisala.com/warranty](http://www.vaisala.com/warranty).

Please observe that any such warranty may not be valid in case of damage due to normal wear and tear, exceptional operating conditions, negligent handling or installation, or unauthorized modifications. Please see the applicable supply contract or Conditions of Sale for details of the warranty for each product.

This page intentionally left blank.

## CHAPTER 2

# PRODUCT OVERVIEW

This chapter introduces the features, advantages, and the product nomenclature of the Vaisala HUMICAP® Moisture and Temperature Transmitter for Oil MMT330.

### Introduction to MMT330

Vaisala HUMICAP® Moisture and Temperature Transmitter for Oil MMT330 provides reliable moisture measurement in a wide range of applications. The easy-to-install on-line MMT330 transmitter is a microprocessor-based instrument for the measurement of moisture in terms of water activity and relative saturation for example in the lubrication of circulation systems or in transformer oil.

The transmitter incorporates a capacitive thin film sensor, the operation of which is based on changes in its capacitance as the thin polymer film absorbs water molecules.

Two analog output signals can be scaled and the measurement ranges changed within certain limits. Analog outputs can be chosen between current and voltage signals. Alternatively, digital outputs RS-232 (standard) or RS-422/485 (optional) can be selected. MMT330 also provides for accurate temperature measurement.

MMT330 can be calibrated against traceable salt solutions and configured in many ways. It can have either a blank cover or a cover with a local display and keypad with which the user can operate the transmitter. Different probe cable lengths are available for varying installation needs, and the power supply voltage can be selected from three alternatives.

**Table 3 Quantities Measured by MMT330**

Quantity	Abbreviation	Metric Unit	Non-Metric Unit
Water activity	AW		
Relative saturation	%RS		
Temperature	T	°C	°F

**Table 4 Optional Quantities Measured by MMT330**

Quantity	Abbreviation	Metric Unit	Non-Metric Unit
ppm (for transformer oil only)	H2O	ppm	ppm

## Basic Features and Options

- Several probes for various applications
- User-friendly display and keypad interface (optional)
- Different probe mounting kits and probe cable lengths
- Transmitter mounting kits for multiple installation purposes
- Support for Modbus serial communications protocol
- USB connectivity for service connections via the optional USB-RJ45 cable
- Optional modules:
  - Isolated power supply
  - Power supply module for AC mains power
  - RS-422/485-module
  - LAN and WLAN interfaces
  - Data logger module with real time clock
  - Additional analog output module
  - Relay module

## Structure of the Transmitter

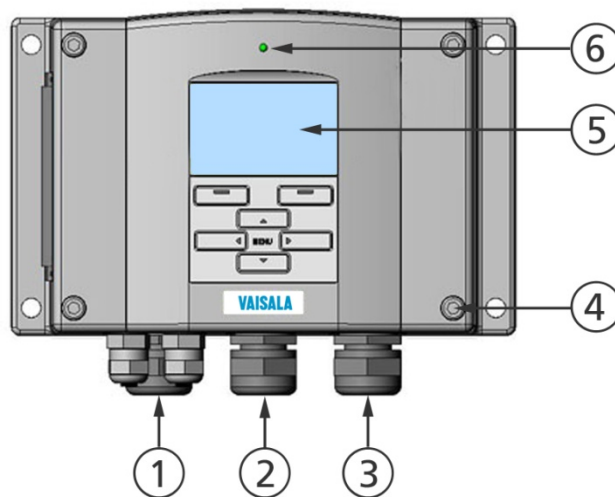

1104-001

**Figure 1** Transmitter Body

The numbers refer to Figure 1 above:

- 1 = Signal + powering cable gland
- 2 = Cable gland for optional module, or WLAN antenna connector
- 3 = Cable gland for optional module or AC mains cable
- 4 = Cover screw (4 pcs)
- 5 = Display with keypad (optional)
- 6 = Cover LED

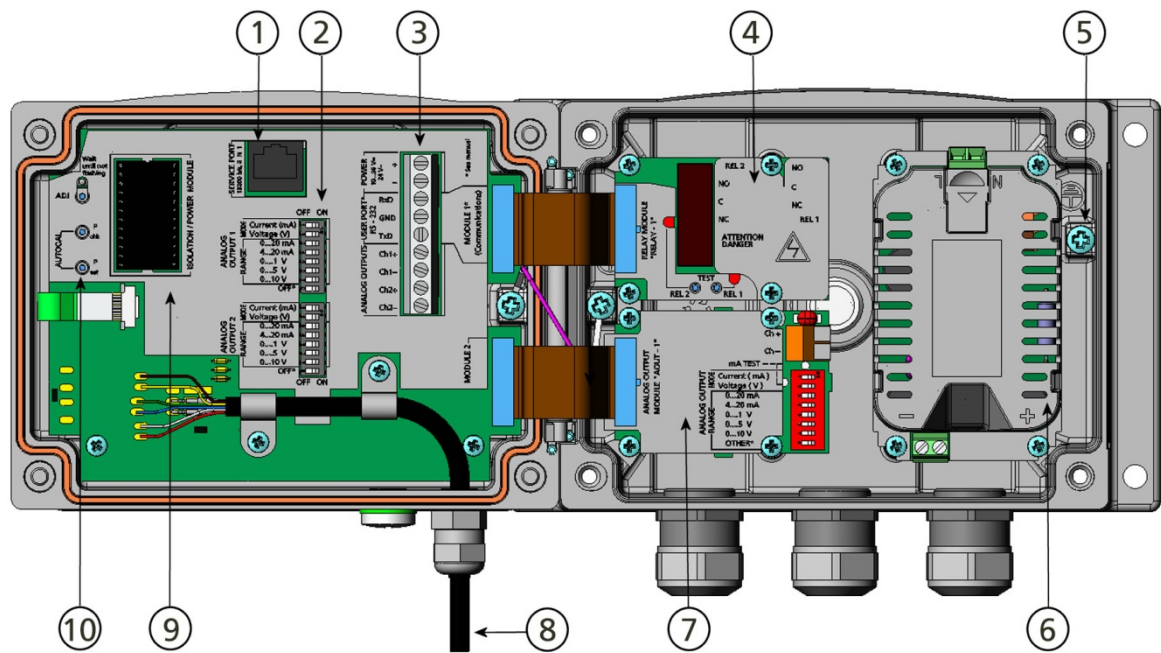

0604-006

**Figure 2** Inside the Transmitter

The following numbers refer to Figure 2 above:

- 1 = Service port (RS-232)
- 2 = DIP switches for analog output settings
- 3 = Power supply and signal wiring screw terminals
- 4 = Relay, data logger, RS-422/485, LAN, or WLAN module (optional)
- 5 = Grounding connector
- 6 = Power supply module (optional)
- 7 = Relay, data logger, or analog output module (optional)
- 8 = Humidity probe cable
- 9 = Galvanic isolation module (optional)
- 10 = Adjustment buttons with indicator LED. Purge is not available.

## Probe Options

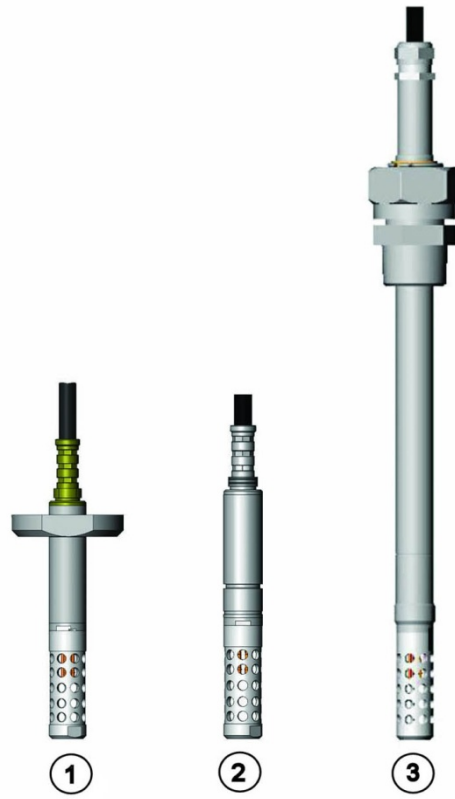

0509-143

**Figure 3**      **Probe Options**

The following numbers refer to Figure 3 above:

- 1 = MMT332 for high-pressure applications
- 2 = MMT337 small pressure-tight probe
- 3 = MMT338 adjustable probe for pressurized pipelines  
(40 bar, ball valve)

For probe cable lengths, see Table 32 on page 162.



## Typical Applications

### Methods Used for Measuring Moisture in Oil

The MMT330 transmitter can measure water in oil in terms of water activity ( $a_w$ ) and relative saturation (%RS). With the help of internal oil solubility coefficients, MMT330 is also able to output oil moisture in ppm (by default supported only for mineral transformer oil).

Water activity indicates the amount of oil in the scale of 0 ... 1  $a_w$ . In this scale, 0  $a_w$  is an indication of completely water free oil, and 1  $a_w$  an indication of oil fully saturated with water (water is present in free form).

Relative saturation indicates the amount of water oil in the scale of 0 ... 100 %RS. In this scale, 0 %RS is an indication of completely water free oil and 100 %RS an indication of oil fully saturated with water (water is present in free form).

The most important feature which distinguishes the measurement of water activity ( $a_w$ ) and relative saturation (%RS) from the traditional measurement of absolute water content (in ppm) is that the saturation point remains stable regardless of the oil type or the aging of oil, additives used, etc. As water activity exceeds 0.9  $a_w$  (or relative saturation exceeds 90 %RS) in any system, there is a risk for segregation (especially if the temperature decreases).

Water activity and relative saturation are used for alarming at the point of  $>0.9 a_w / >90 \%RS$  that the risk for free water in the system is obvious. The most important advantages of this system are the fact that water activity and relative saturation are immune to the aging of oil and to additives, and that the MMT330 transmitter can be used for continuous on-line measurements. In addition, MMT330 can be calibrated against salt solutions and no reference oils are needed.

### Lubrication Oil in Paper Machines

Typically, a paper machine contains two or three separate lubrication systems. Usually, one is located at the wet end and the other at the dry end. There is a certain amount of free moisture constantly present which means that there is a risk of this moisture becoming into contact with the machine bearings. The most common reasons for the entrance of water are an inadequate sealing of the housing and cleaning with high pressure. However, accidental leakages from oil coolers and other equipment may also cause damage. In paper machines, the oil should absorb water while lubricating the bearings and then release this water when collected into the reservoir.

It is to be noted that bearings should never be exposed to oils that have a high water content; this is especially important during standstill because the risk for corrosion process increases as the oil temperature decreases. It is essential to monitor the water content and keep it on a suitable level.

When measuring the water content of oil in paper machines, it would be useful to measure the water activity before an oil reservoir and from a pressure line flow. This way, the performance of dehumidifiers can be kept under control to ensure that no free water reaches the bearings.

## **Transformer Oil**

The determination of moisture in oil is an essential part of a comprehensive transformer maintenance program. Aging and deterioration increase the capacity of oil to absorb water. The primary interest in transformers is to measure the water not in oil but in the cellulosic insulation around the transformer windings. Heating and cooling have a considerable effect on moisture levels in oil. While temperature raises, the paper insulation of transformers tends to loose moisture which is absorbed by the oil surrounding it. Saturation level is thus a true indicator of moisture present. The MMT330 method provides for a reliable detection of the aging of oil and possible leakages.

Oil immersed transformers rely on the oil for cooling, protection from corrosion and as an important component of their insulation. Excessive moisture contents in oil causes accelerated ageing of the insulation materials and reduces their dielectric strength. In extreme cases this can result in arcing and short circuits within the windings. Accurate moisture measurements can also warn about leaks in the oil system, as water is absorbed from the surrounding air.

Heating and cooling of a transformer effect moisture levels in oil. This is due to the fact that the water solubility of oil is temperature dependent. In general, water solubility increases as temperature rises: see Figure 4 on page 25. Changes in temperature affect also on water desorption of the paper insulation around the transformer windings. Desorption of water from the insulation increases as temperature rises and the surrounded oil absorbs desorbed water. Moisture level in oil is thus a true indicator of moisture present in the paper insulation.

In addition, it must be noted that capacity of oil to absorb water depends both on the chemical structure of the oil and the additives.

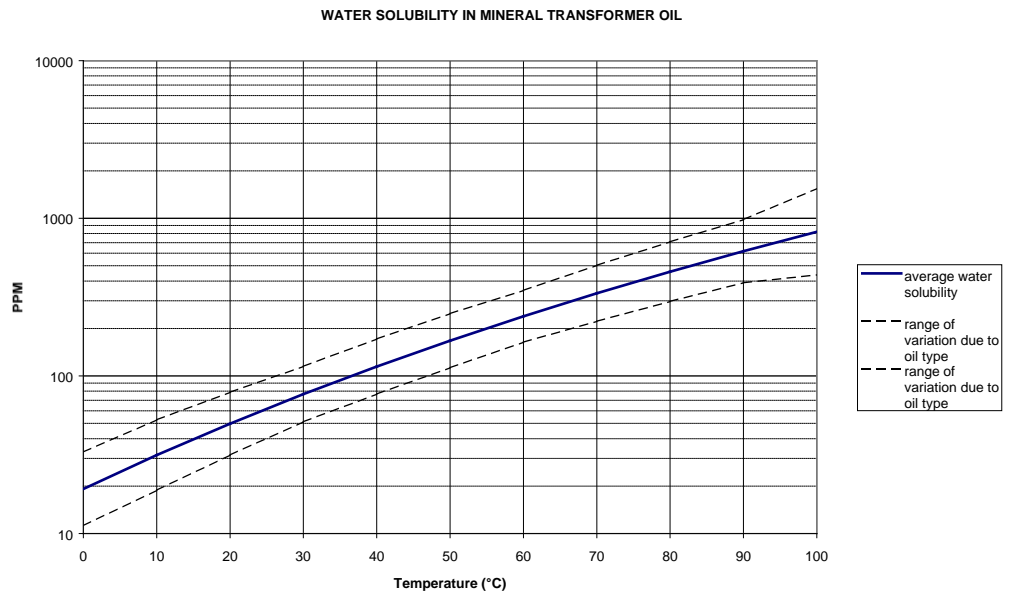

**Figure 4 The Water Solubility of Transformer Oils versus Temperature**

The margins show the range of variation of water solubility found in mineral oils.

This page intentionally left blank.

## CHAPTER 3

# INSTALLATION

This chapter provides you with information that is intended to help you install the product.

## Mounting the Housing

### Standard Mounting

Mount the housing by fastening the transmitter to the wall with 4 screws, for example, M6 (not provided).

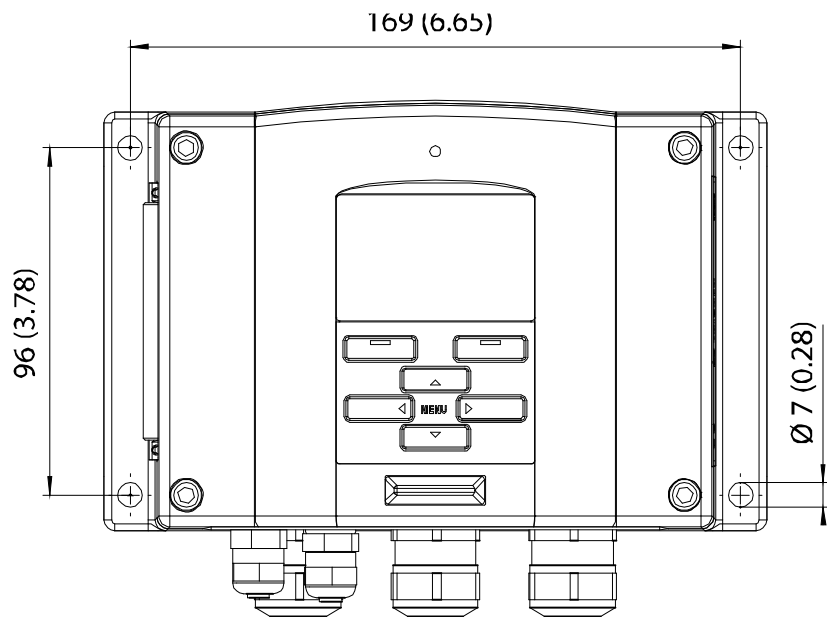

0804-066

**Figure 5** Standard Mounting Dimensions (in mm/inch)

## Wall Mounting with Wall Mounting Kit

When mounting with wall mounting kit the mounting plate (Vaisala order code 214829) can be installed directly on wall or onto a standard wall box (also US junction box). When wiring through back wall, remove the plastic plug from the wiring hole in the transmitter before mounting.

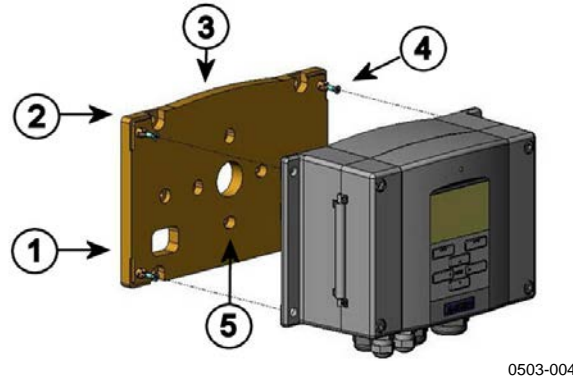

0503-004

**Figure 6 Mounting with Wall Mounting Kit**

The following numbers refer to Figure 6 above:

- 1 = Plastic mounting plate
- 2 = Mount the plate to wall with 4 screws M6 (not provided)
- 3 = Arched side up
- 4 = Fasten MMT330 to the mounting plate with 4 fixing screws M3 (provided)
- 5 = Holes for wall/junction box mounting

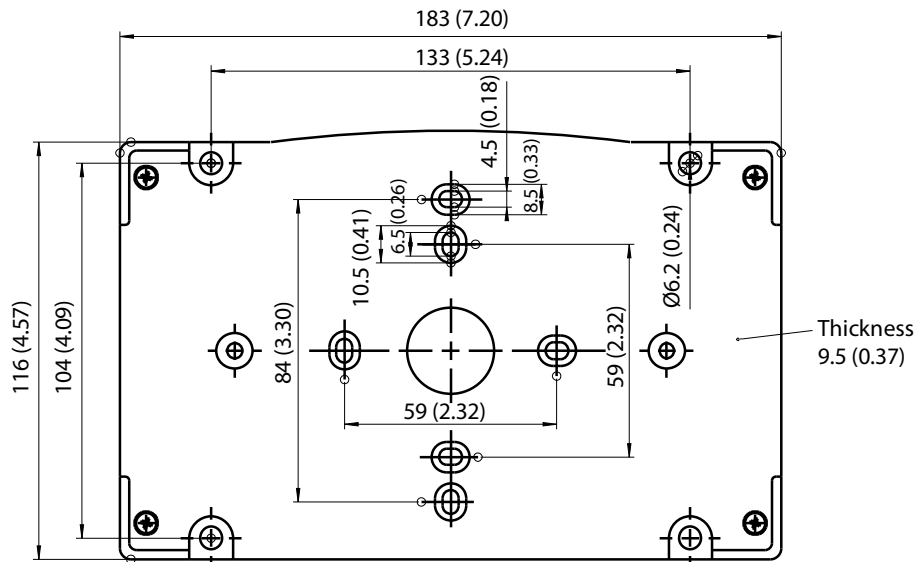

0804-065

**Figure 7 Dimensions of the Plastic Mounting Plate (mm/inch)**

## Mounting with DIN Rail Installation Kit

DIN rail installation kit includes a wall mounting kit, 2 clip-fasteners, and 2 screws M4 x 10 DIN 7985 (Vaisala order code: 215094).

1. Attach two spring holders to the plastic mounting plate by using the screws provided in the installation kit.
2. Fasten MMT330 to the plastic mounting plate with 4 screws (provided).
3. Press the transmitter onto the DIN rail so that the clip-fasteners snap into the rail.

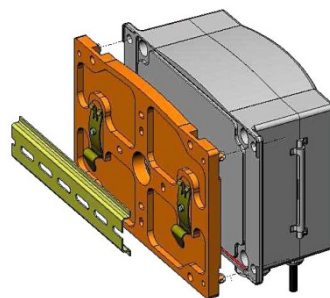

0503-002

**Figure 8** Mounting with DIN Rail Installation Kit

## Pole Installation with Installation Kit for Pole or Pipeline

Installation kit for pole or pipeline (Vaisala order code: 215108) includes the metal mounting plate and 4 mounting nuts for pole mounting. When mounting, the arrow in the metal mounting plate must point upward, see Figure 11 on page 30.

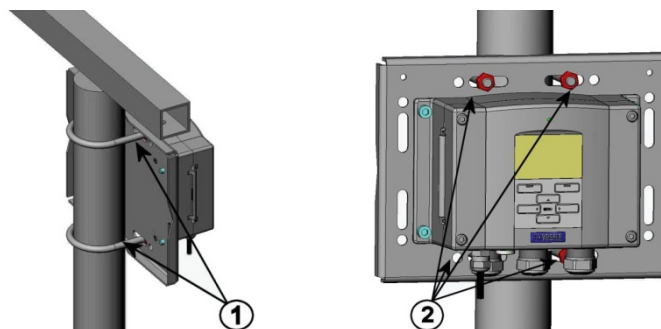

0503-006

**Figure 9** Vertical Pole

The following numbers refer to Figure 9 above:

- 1 = Fixing brackets (2 pcs) M8 (provided) for 30 ... 102 mm poles
- 2 = Mounting nuts M8 (4 pcs)

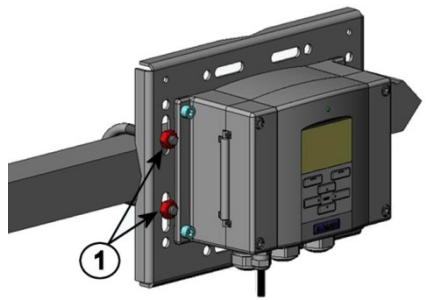

0503-007

**Figure 10 Horizontal Pole**

The following number refers to Figure 10 above:

- 1 = Mounting nuts M8 (4 pcs)

Metal mounting plate is included in rain shield with installation kit and installation kit for pole or pipeline.

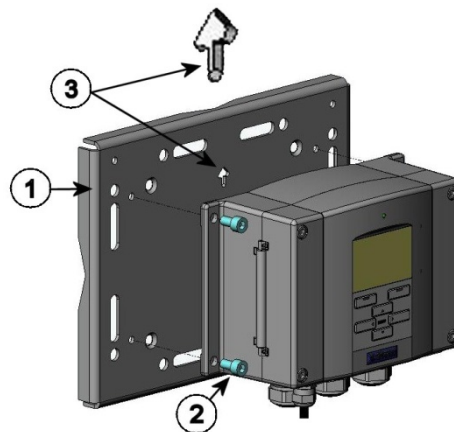

0503-041

**Figure 11 Mounting with Metal Wall Mounting Plate**

The following numbers refer to Figure 11 above:

- 1 = Mount the plate to wall with 4 screws M8 (not provided)
- 2 = Fasten MMT330 to the mounting plate with 4 fixing screws M6 (provided)
- 3 = Note the position of the arrow when mounting. This side must be up when mounting.



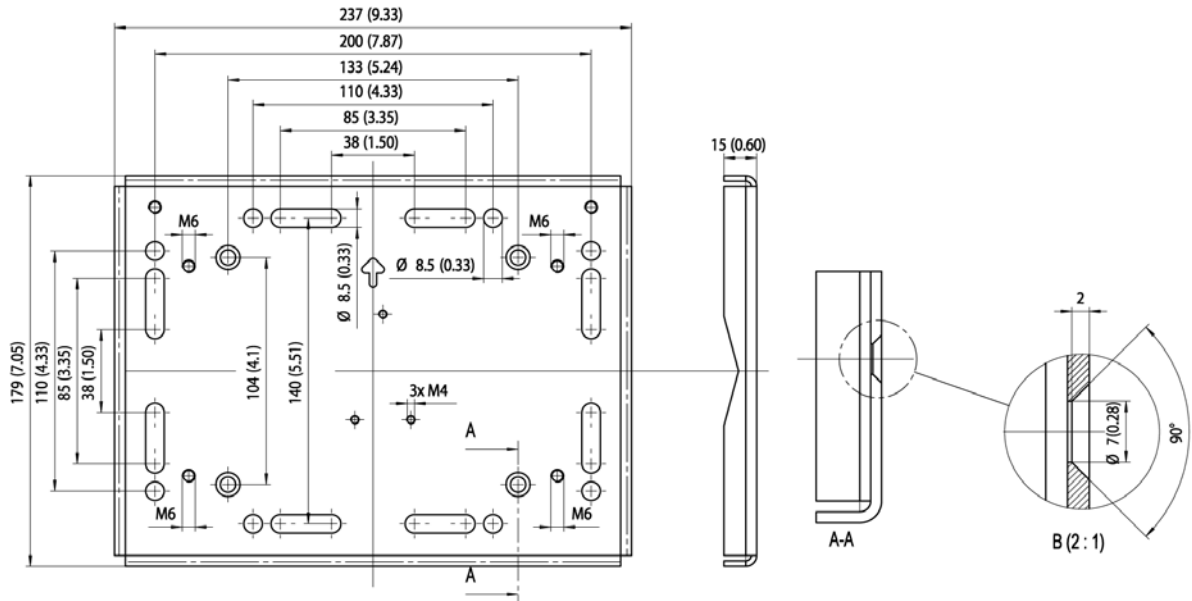

0509-051

**Figure 12** Dimensions of Metal Mounting Plate (mm/inch)

## Mounting Rain Shield with Installation Kit

The rain shield is highly recommended for outdoor installations, especially for transmitters with the display/keypad option.

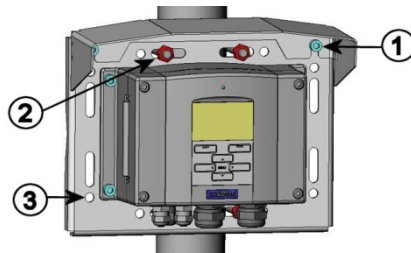

0503-008

**Figure 13** Mounting Rain Shield with Installation Kit

The following numbers refer to Figure 13 above:

- 1 = Fasten the rain shield with installation kit (Vaisala order code: 215109) to the metal mounting plate with 2 (M6) mounting screws (provided)
- 2 = Fasten the mounting plate with rain shield with installation kit to the wall or to the pole (see pole installation)
- 3 = Fasten the MMT330 to the mounting plate with 4 fixing screws (provided)

## Panel Mounting Frame

To enable a neat and dirt free embedded installation of the transmitter, a panel mounting frame is available as an option (Vaisala order code: 216038). The frame is a thin, flexible plastic frame for the transmitter, with adhesive tape on one side.

The frame is used to hide any rough edges of the installation hole, and provide a more finished look. Note that the panel mounting frame is not intended to bear the weight of the transmitter, and does not include any mounting supports.

Use the panel mounting frame as follows:

1. Use the frame as a template to mark the required size for the installation hole in the panel.
2. Cut the hole in the panel.
3. Mount the transmitter through the panel with suitable supports.
4. Remove the paper protecting the adhesive tape on the frame, and attach the frame around the transmitter. Refer to Figure 14 on page 32.

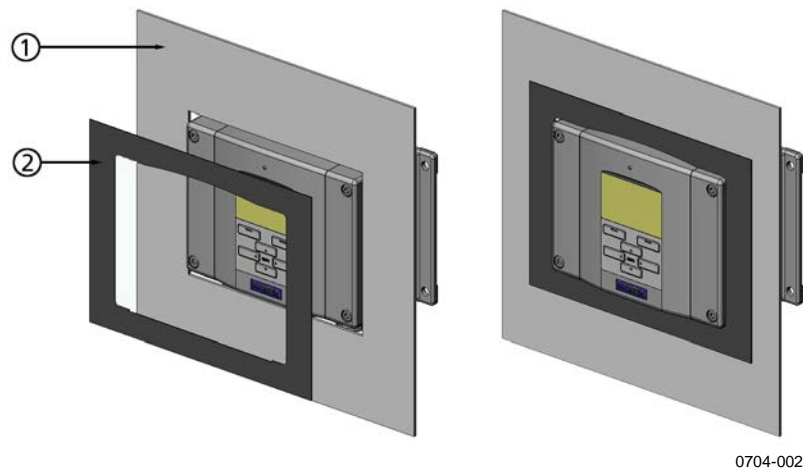

**Figure 14** Panel Mounting Frame

The following numbers refer to Figure 14 above:

- |   |   |                      |
|---|---|----------------------|
| 1 | = | Panel (not included) |
| 2 | = | Panel mounting frame |

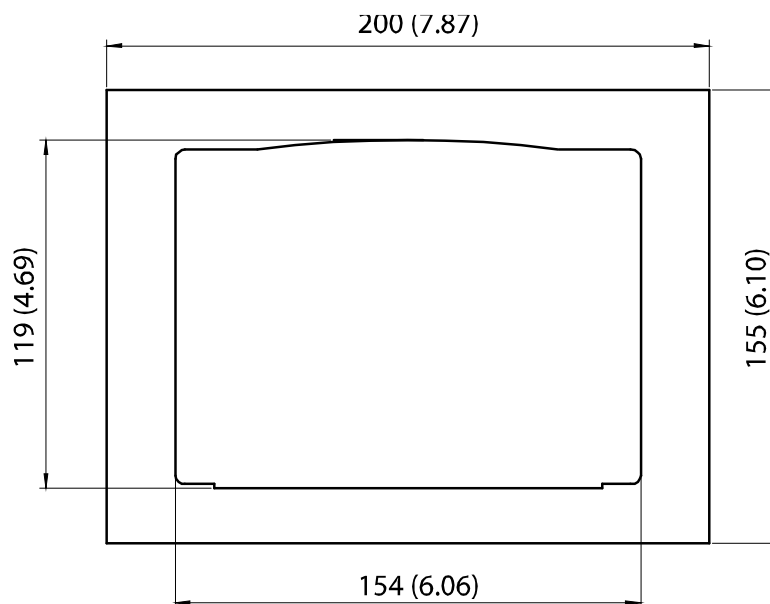

0804-083

**Figure 15 Panel Mounting Dimensions (mm/inch)**

## Wiring

### Cable Bushings

A single electrical cable with a screen and three to ten wires is recommended for power and analog/serial connections. The cable diameter should be 8 ... 11 mm. The number of cable bushings depends on the transmitter options. See the following recommendations for the cable bushings:

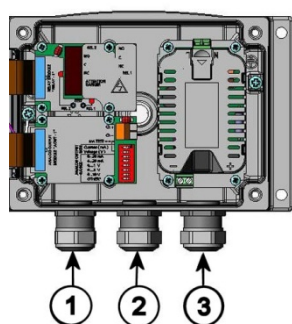

0503-010

**Figure 16 Cable Bushings**

The following numbers refer to Figure 16 above:

- 1 = Cable for signal/powering Ø8 ... 11 mm
- 2 = Cable for optional module Ø8 ... 11 mm
- 3 = Cable for optional power supply module Ø8 ... 11 mm

**NOTE**

When there is high electric noise level (for example, near powerful electric motor) in the operating environment it is recommended to use shielded cable or take care that the signal cables are separated from other cables.

## Grounding the Cables

Ground the screen of the electrical cable properly to achieve the best possible EMC performance.

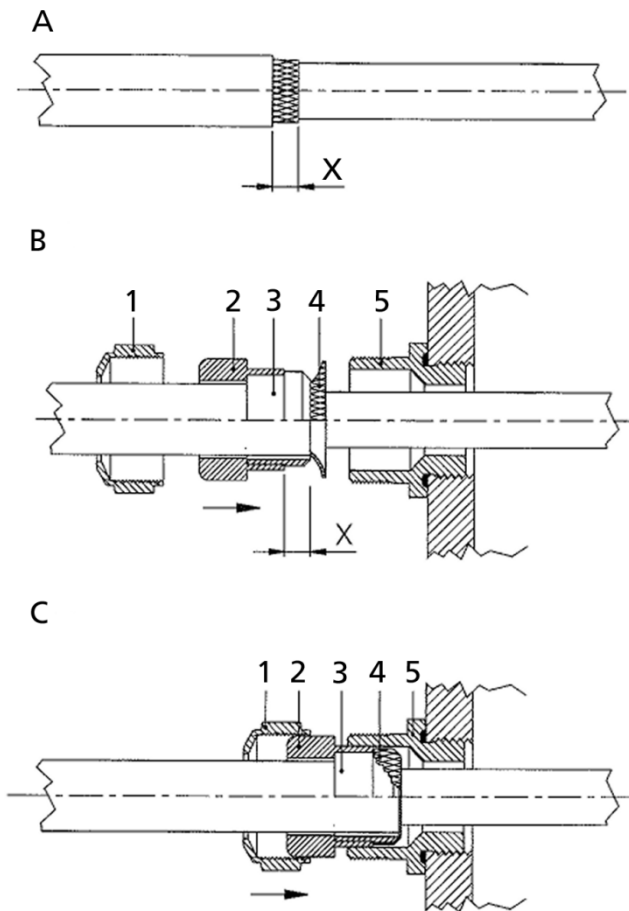

0605-027

**Figure 17** Grounding the Screen of Electrical Cable

Refer to Figure 17 on page 34 when performing the procedure below.

1. Cut back outer sheath to desired length.
2. Cut back screen braiding or screen foil to dimension X.
3. Push the domed cap nut (item 1) and the seal insert with contact socket of the gland (item 2+3) onto the cable as shown in the diagram.
4. Bend over the screen braiding or screen foil by about 90° (item 4).
5. Push the seal insert with the contact socket of the gland (item 2+3) up to the screen braiding or screen foil.
6. Mount the lower part (item 5) on the housing.
7. Push the seal with the contact socket of the gland (item 2+3) into the lower part (item 5).
8. Fasten the domed cap nut (item 1) onto the lower part (item 5).

## Grounding the Transmitter Housing

In case you need to ground the transmitter housing, the grounding connector is found inside the housing; see Figure 2 on page 21.

Make sure that the probe is connected to the same potential as the housing. Make sure that different groundings are made to the same potential. Otherwise harmful ground currents may be generated.

If it is needed to have galvanic isolation of the power supply line from the output signals, MMT330 can be ordered with optional galvanic isolation module. This module prevents harmful grounding loops.

## Signal and Power Supply Wiring

When connecting transmitter with 8-pin connector, see section 8-Pin Connector on page 65. When wiring the power supply module, see section Power Supply Module on page 48.

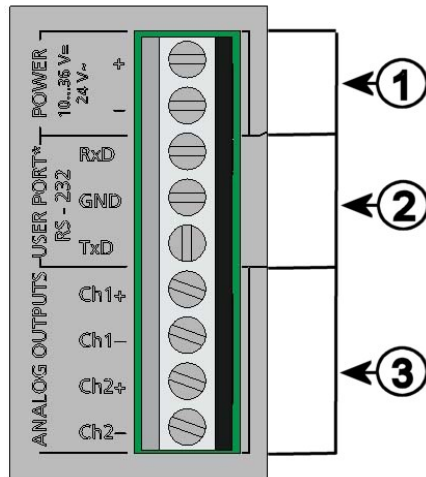

0506-028

**Figure 18 Screw Terminal Block on Motherboard**

The following numbers refer to Figure 18 above:

- 1 = Power supply terminals 10 ... 35 VDC, 24 VAC
- 2 = User port (RS-232 terminals)
- 3 = Analog signal terminals

**WARNING** Make sure that you connect only de-energized wires.

1. Open the transmitter cover by taking out the four cover screws.
2. Insert the power supply wires and signal wires through the cable bushing in the bottom of the transmitter; see the grounding instructions in the previous sections.
3. Connect the analog output cables to terminals: **Ch1 +, Ch1-, Ch2+, Ch2-**. Connect the RS-232 user port cables to terminals RxD, GND and TxD. For more information about the RS-232 connection refer to section Serial Line Communication on page 78.
4. When wiring the optional modules, see the corresponding section for instructions:
  - RS-422/485 Interface on page 56
  - Relays on page 55
  - Third Analog Output on page 53
  - LAN Interface on page 61
  - WLAN Interface on page 62
5. Connect the power supply wires to the connectors: **POWER 10...35V+ 24V~ (+) and (-)** terminals. If you are using 24 VAC power supply, see the note below before connecting the supply wires.
6. Turn on the power. The indicator LED on the cover is lit continuously during normal operation.
7. Close the cover and replace the cover screws. The transmitter is ready for use.

## Connections to a 24 VAC Power Supply

Separate floating supply for each transmitter is recommended (see the upper part of Figure 19 on page 38). If you have to connect several transmitters or other instruments to one AC supply, the phase (~) must always be connected to the (+) connector of each transmitter (see the lower part of Figure 19).

**CAUTION 24 VAC POWER SUPPLY USE**

To prevent fire and/or damage, if either 24 VAC wire is grounded or connected to a "-", "0", or "GND" terminal of any other device, you must connect the same wire on the "-" terminal also on this instrument.

No common loop - RECOMMENDED!

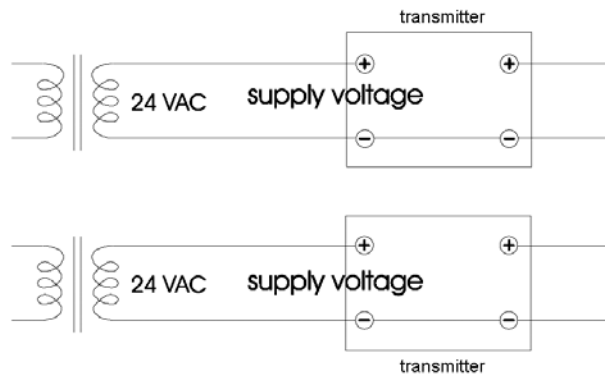

Common loop formed - NOT recommended!

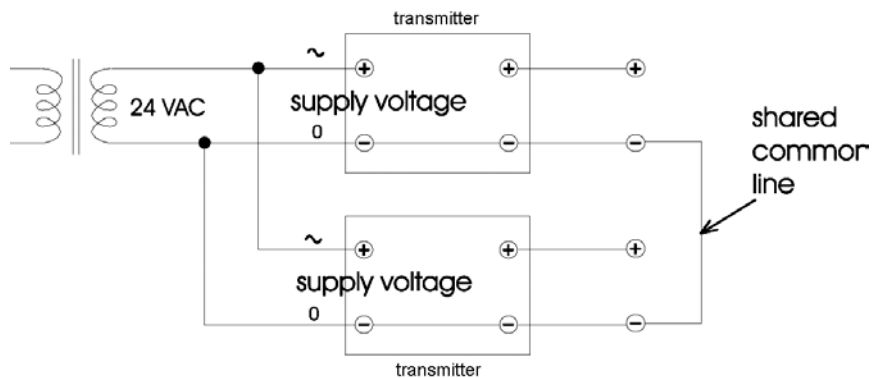

0703-041

**Figure 19 Connections to 24 VAC Power Supply**



## MMT332 for High-Pressure Applications

The MMT332 probe is a small, pressure-tight probe equipped with an installation flange. It is suitable for high-pressure applications (up to 250 bar).

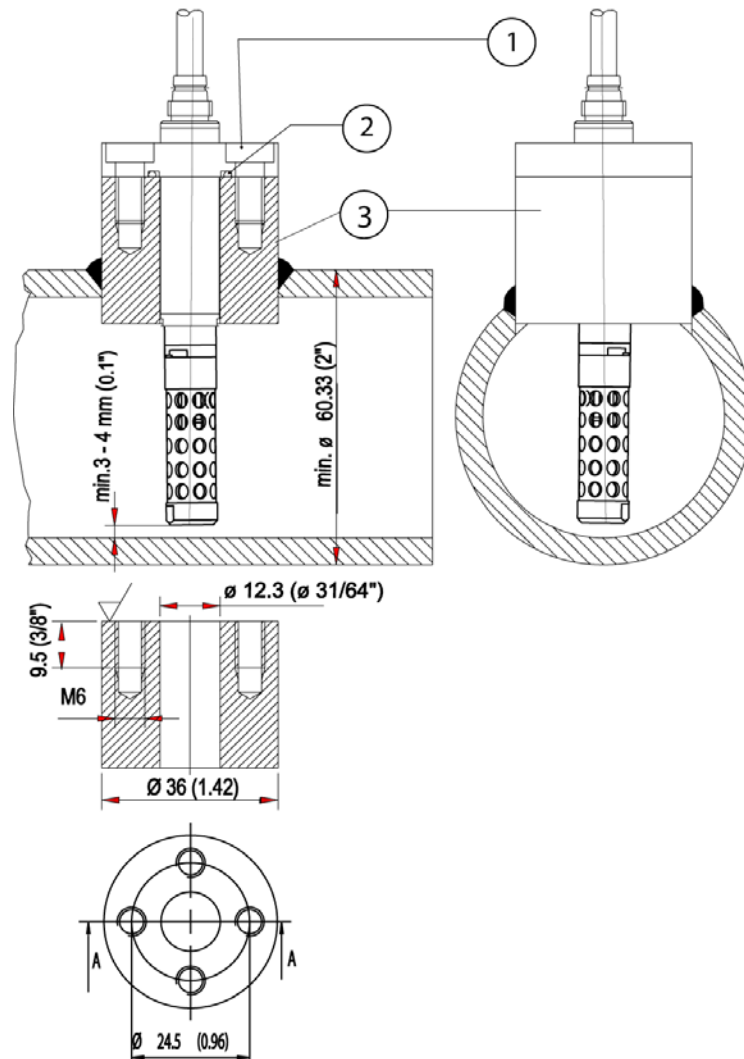

0510-030

**Figure 20 MMT332 Installation**

The following numbers refer to Figure 20 above:

- 1 = Screw, 4 pcs, hexagon socket head (provided)
- 2 = O-ring (provided)
- 3 = Threaded sleeve (not provided)

## MMT337 Small Pressure-Tight Probe

The MMT337 is ideal for tight spaces with a threaded connection. The small probe is installed using the threaded fitting bodies; see next section.

## MMT337 Probe with Swagelok Connector for Tight-place Installations

Swagelok installation kit for the MMT337 probe includes Swagelok connector with ISO3/8" thread ( Vaisala order code: SWG12ISO38) or NPT1/2" thread (Vaisala order code:SWG12NPT12).

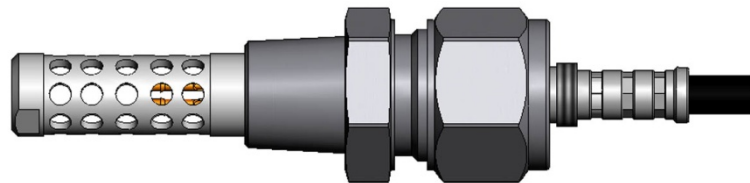

0509-144

**Figure 21** MMT337 Probe with Swagelok Installation Kit

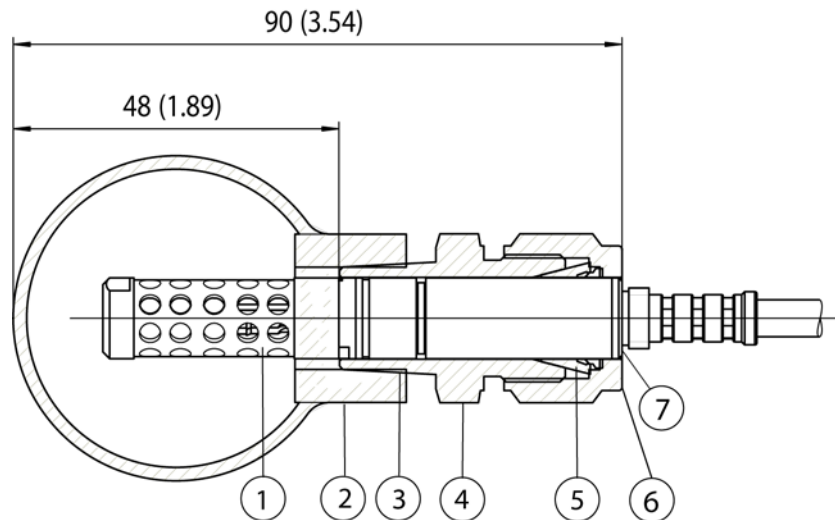

0509-150

**Figure 22** MMT337 Probe Installation to Pipeline with Swagelok Installation Kit

The following numbers refer to Figure 22 above:

- 1 = Probe
- 2 = Duct connector
- 3 = ISO3/8" or NPT1/2" thread
- 4 = Swagelok connector
- 5 = Ferrules
- 6 = Upper edge of the connector nut
- 7 = Upper edge of the probe

1. Preparing installation. The connector options are the following:
  - a. R3/8" ISO (Swagelok code SS-12M0-1-6RTBT)
  - b. 1/2" NPT (Swagelok code SS-12M0-1-8BT)Note that the connector inner diameters extend for Ø12 mm probe.
2. Probe position. Before the final tightening check that the upper edge of the connector nut is in line with the upper edge of the probe. Otherwise the sealing may not be gas tight.
3. Gas tight sealing
  - a. Turn the connector nut finger tight and draw a vertical mark on the nut and the fitting body.
  - b. Be sure that the probe position follows step 2.
  - c. Tighten the connector nut with a wrench 1 and 1/4 turns ( $360^\circ + 90^\circ$ ) with the help of the marks you drew. The connector has now a gas tight connection to the probe. Excess tightening can damage the probe.
  - d. Connector can be disconnected and re-installed. In re-installation first turn the connector nut finger tight and then with wrench 1/4 turn ( $90^\circ$ ).

Use teflon tape or thread sealant to seal the connection between the Swagelok connector and the process; see Figure 24 on page 43.

## MMT338 for Pressurized Pipelines

Due to the sliding fit, the MMT338 is easy to install into and remove from the pressurized process. The probe is especially suitable for the measurements in pipelines. The probe is adjustable, with two length options. The installation is easy due to the ball valve installation kit; see below.

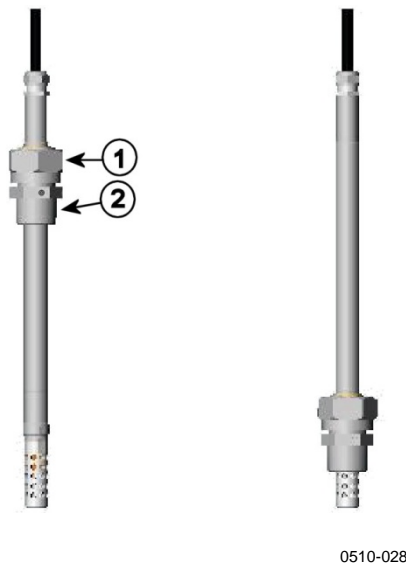

**Figure 23 MMT338 Probe**

The following numbers refer to Figure 23 above:

- 1 = Clasp nut, 24 mm hex nut
- 2 = Fitting body, 27 mm hex head

The following two fitting body options are available:

- Fitting Body ISO1/2 solid structure
- Fitting Body NPT1/2 solid structure

**Table 5 MMT338 Probe Dimensions**

Probe type	Probe Dimension	Adjustment Range
Standard	178 mm	120 mm
Optional	400 mm	340 mm

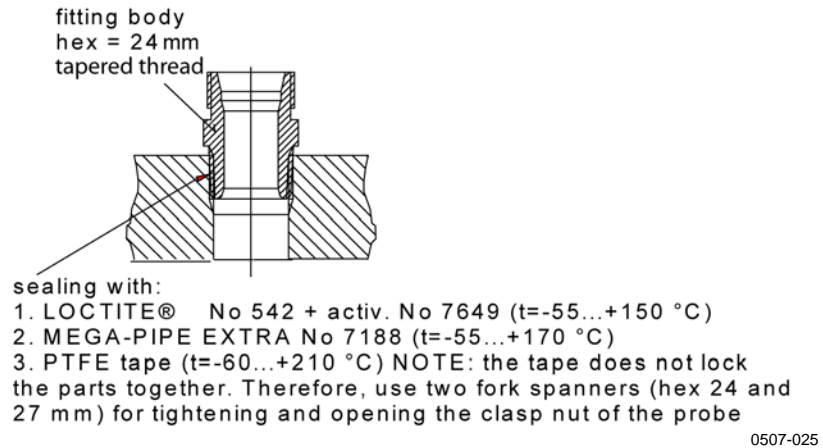

**Figure 24** Sealing of Fitting Body into Process

## Tightening the Clasp Nut

1. Adjust the probe to a suitable depth according to the type of installation.
2. Tighten the clasp nut first manually.
3. Mark the fitting screw and the clasp nut.
4. Tighten the nut a further 50 ... 60° (ca. 1/6 turn) with a wrench. If you have suitable torque spanner, tighten the nut to max 45 ±5 Nm (33 ±4 ft-lbs). See notes on the following page.

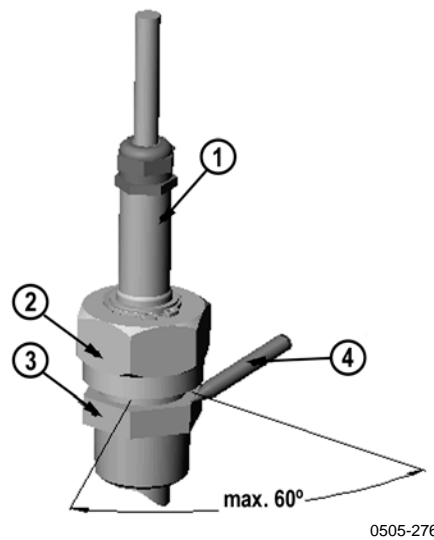

**Figure 25** Tightening the Clasp Nut

The following numbers refer to Figure 25 above:

- |   |   |               |
|---|---|---------------|
| 1 | = | Probe         |
| 2 | = | Clasp nut     |
| 3 | = | Fitting screw |
| 4 | = | Pen           |

**CAUTION** Take care not to damage the probe body. A damaged body makes the probe less tight and may prevent it from going through the clasp nut.

**CAUTION** In pressurized processes it is essential to tighten the supporting nuts and screws very carefully to prevent loosening of the probe by the action of pressure.

**NOTE** Take care not to over tighten the clasp nut to avoid difficulties when opening it.

## Ball Valve Installation Kit for MMT338

The ball valve installation kit (Vaisala order code: BALLVALVE-1) is preferred when connecting the probe to a pressurized process or pipeline. Use the ball valve set or a 1/2" ball valve assembly with a ball hole of  $\varnothing 14$  mm or more. If you install the probe ( $\varnothing 12$  mm) in a process pipe, please note that the nominal size of the pipe must be at least 1 inch (2.54 cm). Use the manual press handle to press the probe into the pressurized (< 10 bar) process or pipeline.

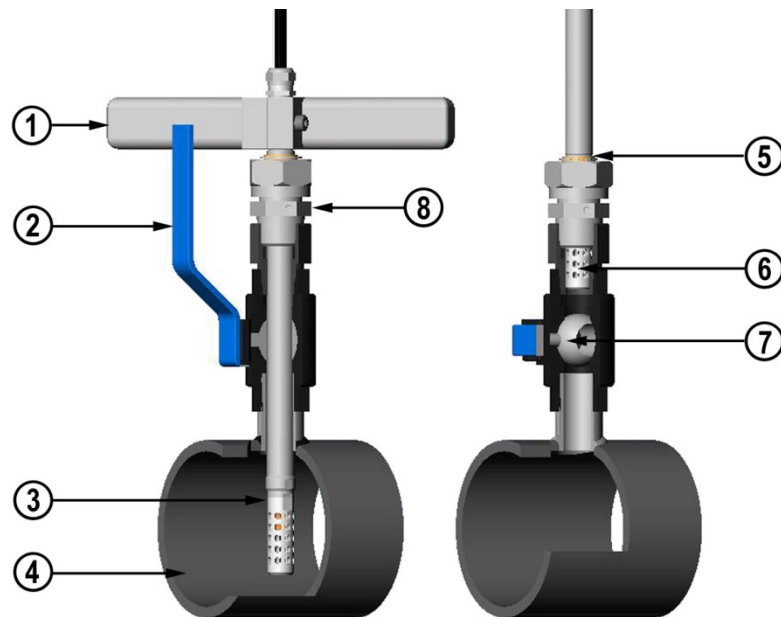

0507-043

**Figure 26** Installing the MMT338 Probe through a Ball Valve Assembly

The following numbers refer to Figure 26:

- 1 = Manual press tool
- 2 = Handle of the ball valve
- 3 = Probe
- 4 = Process chamber or pipeline
- 5 = Groove on the probe indicates the upper adjustment limit
- 6 = Filter
- 7 = Ball of the ball valve
- 8 = Fitting screw

**NOTE**

The probe can be installed in the process through the ball valve assembly provided that the process pressure is less than 10 bars. This way, the process does not have to be shut down when installing or removing the probe. However, if the process is shut down before removing the probe, the process pressure can be max. 20 bars.

**NOTE**

When measuring temperature dependent quantities make sure that the temperature at the measurement point is equal to that of the process, otherwise the moisture reading may be incorrect.

Follow the steps below to install the MMT338 probe through a ball valve assembly. After the installation, the probe should be sitting in the process chamber or pipeline as shown in Figure 26 on page 45.

1. Shut down the process if the process pressure is more than 10 bars. If the pressure is lower there is no need to shut down the process.
2. Close the ball valve.
3. Seal the threads on the fitting body; refer to Figure 24 on page 43.
4. Attach the fitting body to the ball valve and tighten it.
5. Slide the clasp nut of the probe toward the filter, as far as it will go.
6. Insert the probe to the fitting body, and manually tighten the clasp nut to the fitting body.
7. Open the ball valve.
8. Push the probe through the ball valve assembly into the process. If the pressure is high, use the pressing handle that is provided with the probe. If you push the probe hard without using the handle, you may damage the cable.

Note that the probe must be pushed so deep that the filter is completely inside the process flow.

9. Mark the fitting screw and the clasp nut.
10. Tighten the clasp nut with a fork spanner a further 50 ... 60° (ca. 1/6 turn). If you have a suitable torque spanner, tighten the nut to max  $45 \pm 5$  Nm ( $33 \pm 4$  ft-lbs). Refer to Figure 25 on page 43.

**NOTE**

Take care not to tighten the clasp nut more than 60° to avoid difficulties when opening it.

If you wish to remove the probe from the process, note that you have to pull the probe out far enough. You cannot close the valve if the groove on the probe body is not visible.



## Sampling Cell for MMT338

It may be necessary to use a sampling cell if the MMT338 probe cannot be installed directly into the process pipe, for example, if the pipe is too small for the probe. Then, a by-pass sampling line may be feasible.

Sampling Cell with Swagelok Connectors (Vaisala order code: DMT242SC2) is available as an optional accessory.

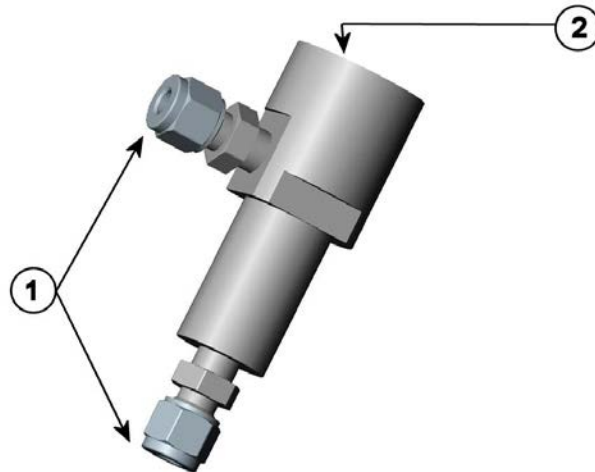

0511-108

**Figure 27** Sampling Cell DMT242SC2

The following numbers refer to Figure 27 above:

- 1 = Male pipe weld connector Swagelok 1/4"
- 2 = G1/2"

## Optional Modules

### Power Supply Module

The AC (mains) power connection may be connected to the power supply module only by an authorized electrician. A readily accessible disconnect device shall be incorporated in the fixed wiring.

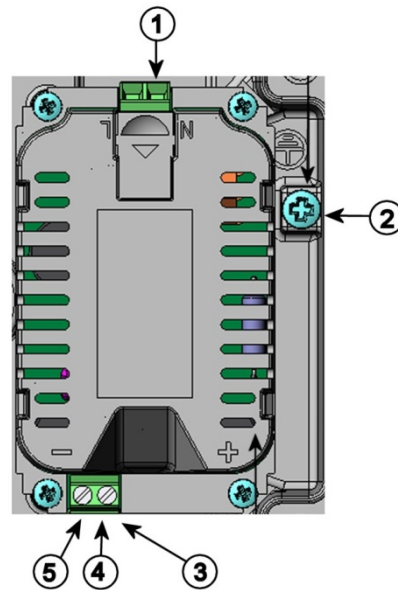

0506-027

**Figure 28** Power Supply Module

The following numbers refer to Figure 28 above:

- 1 = Connect AC (mains) voltage wires to these terminals
- 2 = Grounding terminal
- 3 = In case the module is not installed in the factory, connect wires from these terminals to the **POWER 10 ... 35V 24V** terminals in the screw terminal of the motherboard.
- 4 = +
- 5 = -

## Installation

1. Disconnect the power and open the transmitter cover.
2. Remove the protective plug from the cable gland and thread the wires. In case the power supply module is installed in the factory, continue with the step 5.
3. To attach the module fasten the power module to the bottom of the housing with four screws. See the position in Figure 2 on page 21.
4. Connect the wires from the terminals of the power supply module marked with + and - to the terminals **POWER 10... 35 V 24V** on the motherboard of the transmitter.
5. Connect the AC mains voltage wires to the power supply module terminals marked with **N** and **L**.
6. Attach the grounding wire to the grounding terminal on the right-hand side of the transmitter.
7. Connect the power. The LED on the cover of the transmitter is lit continuously during normal operation.

**WARNING** Do not detach the power supply module from the transmitter when the power is on.

**WARNING** Do not connect the mains power to power supply module when it is not installed in the transmitter.

**WARNING** Always connect protective ground terminal.

## Warnings

### **Dieses Produkt entspricht der Niederspannungsrichtlinie (2006/95/EWG).**

- Das Netzmodul darf nur von einem dazu befugten Elektriker angeschlossen werden.
- Trennen Sie das Netzmodul nicht vom Messwertgeber, wenn der Strom eingeschaltet ist.
- Verbinden Sie das Netzmodul nur mit der Spannungsquelle, wenn es im Messwertgeber MMT330 montiert ist.
- Das Erdungskabel muss zum Schutz immer angeschlossen sein.

### **Ce produit est conforme à la Directive relative à la Basse Tension (2006/95/EEC).**

- Seul un électricien compétent est habilité à raccorder le module d'alimentation au secteur.
- Ne pas détacher le module d'alimentation du transmetteur lorsqu'il est en service.
- Ne pas raccorder le secteur au module d'alimentation lorsque celui-ci n'est pas installé dans le transmetteur MMT330.
- Toujours raccorder un bornier de protection à la terre.

### **Tämä tuote on pienjännitedirektiivin (2006/95/EEC) mukainen.**

- Vaihtovirtaliitännän saa kytkeä tehonsyöttömoduuliin ainoastaan valtuutettu sähköasentaja.
- Älä irrota tehonsyöttömoduulia lähettimestä, kun virta on kytkettyä.
- Älä kytke verkkovirtaa tehonsyöttömoduuliin, jos kyseistä moduulia ei ole asennettu MMT330 lähettimeen.
- Kytke aina maadoitusliittimet.

### **Denna produkt uppfyller kraven i direktivet om lågspänning (2006/95/EEC).**

- Nätanslutningen (växelströmsanslutningen) får bara anslutas till strömförsörjningsmodulen av en behörig elektriker.
- Ta inte loss strömförsörjningsmodulen från mätaren när strömmen är på.
- Anslut inte strömförsörjningsmodulen till nätet när den inte är installerad i MMT330-mätaren.
- Anslut alltid en skyddande jordningsplint.

### **Questo prodotto è conforme alla Direttiva sul basso voltaggio (2006/95/CEE).**

- La conduttura elettrica può essere collegata al modulo di alimentazione elettrica soltanto da un elettricista autorizzato.
- Non staccare l'alimentazione elettrica dal trasmettitore quando è acceso.
- Non collegare la corrente elettrica al modulo di alimentazione elettrica se non è installato nel trasmettitore MMT330.
- Collegare sempre il morsetto protettivo a terra!

**Dette produkt er i overensstemmelse med direktivet om lavspænding (2006/95/EØS).**

- Netstrømskoblingen til må kun tilsluttes strømforsyningsmodulet af en autoriseret elinstallatør
- Strømforsyningsmodulet må ikke løsgøres fra senderen, mens spændingen er sluttet til.
- Slut ikke netspændingen til strømforsyningsmodulet, når det ikke er installeret i MMT330-senderen
- Forbind altid den beskyttende jordklemme!

**Dit product voldoet aan de eisen van de richtlijn 2006/95/EEG (Laagspanningsrichtlijn).**

- De stroom kan aan de stroomtoevoer module aangesloten worden alleen door een bevoegde monteur.
- Het is niet toegestaan de stroomtoevoer module van de transmitter los te koppelen wanneer de stroom aan is.
- Het is niet toegestaan de stroom aan de stroomtoevoer module aan te sluiten als deze niet in een MMT330-transmitter is gemonteerd.
- Altijd beschermend aardcontact aansluiten!

**Este producto cumple con la directiva de bajo voltaje (2006/95/EEC).**

- La conexión de la alimentación principal al módulo de alimentación sólo puede realizarla un electricista autorizado.
- No desenchufe el módulo de alimentación del transmisor cuando esté encendido.
- No conecte la alimentación principal al módulo de alimentación cuando no esté instalado en el transmisor MMT330.
- Conecte siempre el terminal de protección de conexión a tierra.

**See toode vastab madalpinge direktiivile (2006/95/EEC).**

- Voolukaabli võib vooluallika mooduli külge ühendada ainult volitatud elektrik.
- Ärge ühendage vooluallika moodulit saatja küljest lahti, kui vool on sisse lülitatud.
- Ärge ühendage voolukaablit vooluallika mooduli külge, kui seda pole MMT330-tüüpi saatjasse paigaldatud.
- Ühendage alati kaitsev maandusklemm!

**Ez a termék megfelel a Kiszültségű villamos termékek irányelvnek (2006/95/EGK).**

- A hálózati feszültséget csak feljogosított elektrotechnikus csatlakoztathatja a tápegységmodulra.
- A bekápcolt távadóról ne csatlakoztassa le a tápegységmodult.
- Ne csatlakoztassa a hálózati feszültséget a tápegységmodulhoz, ha az nincs beépítve a MMT330 távadóba.
- Feltétlenül csatlakoztasson földelő védőkapcsot!

**Šis produktas atitinka direktyvą dėl žemos įtampos prietaisų (2006/95/EB).**

- Elektros tinklą su energijos tiekimo modulių sujungti gali tik įgaliotas elektrikas.
- Niekada neišimkite energijos tiekimo modulio iš siūstuvo, kai maitinimas yra įjungtas.
- Jei energijos tiekimo modulis nėra įmontuotas MMT330 siūstuve, neįjunkite jo į elektros tinklą.
- Visada prijunkite prie apsauginės įžeminimo jungties!

**Šis produktas atbilst Zemsprieguma direktivai (2006/95/EEC).**

- Strāvas pieslēgumu var pieslēgt pie barošanas avota moduļa tikai autorizēts elektriķis.
- Neatvienot barošanas avota moduli no raidītāja, kad pieslēgta strāva.
- Nepievienot strāvu barošanas avota modulim, ja tas nav uzstādēts MMT330 raidītājā
- Vienmēr pievienot aizsargājošu iezemētu terminālu !

**Ten produkt spełnia wymogi Dyrektywy niskonapięciowej (2006/95/EEC).**

- Napięcie zasilające powinno zostać podłączone do modułu zasilacza tylko przez wykwalifikowanego elektryka.
- Nie wolno odłączać modułu zasilacza od nadajnika, kiedy zasilanie jest włączone.
- Nie wolno podłączać napięcia zasilającego do modułu zasilacza, kiedy nie jest on zamontowany w nadajniku MMT330.
- Zawsze należy podłączać zabezpieczający zacisk uziemiający!

**Tento výrobek vyhovuje Směrnici pro nízké napětí (2006/95/EEC).**

- Připojení síťového napájení k napájecímu modulu smí provádět pouze oprávněný elektrikář.
- Neodpojujte napájecí modul od snímače při zapnutém napájení.
- Nepřipojujte síťové napájení k napájecímu modulu, pokud není instalován ve snímači MMT330.
- Vždy zapojte ochrannou zemnicí svorku!

## Galvanic Isolation for Power Supply

If galvanic isolation of the power supply line from the output signals is needed, MMT330 can be ordered with optional galvanic isolation module. This module prevents harmful grounding loops.

### NOTE

Galvanic isolation module is not needed when using the AC power supply module. Note also that these two modules are physically incompatible to be installed at the same time. If both modules are installed, there is no room to close the transmitter cover completely.

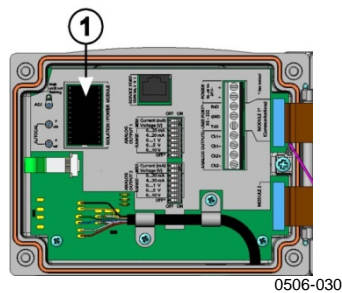
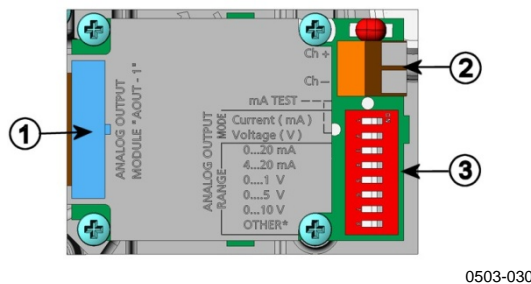

**Figure 29 Galvanic Isolation Module**

Number refers to Figure 29 above:

1 = Galvanic isolation module

## Third Analog Output



**Figure 30 Third Analog Output**

The following numbers refer to Figure 30 above:

- 1 = Flat cable pins
- 2 = Screw terminals for signal line
- 3 = DIP switches to select the output mode and range

## Installation and Wiring

1. Disconnect the power. In case the analog output module is installed in the factory, continue with the step 4.
2. To attach the module, open the transmitter cover and fasten the analog output module to the position for MODULE 2 with four screws. Refer to Figure 2 on page 21.
3. Connect the flat cable between the analog output module and the motherboard's connector for MODULE 2.
4. Take out the protective plug from the cable gland and thread the wires.
5. Connect the wires to the screw terminals marked with **Ch+** and **Ch-**.
6. Select the current/voltage output by setting ON either of the switches 1 or 2.
7. Select the range by setting ON one of the switches 3...7.

**NOTE**

Only one of the switches 1 ... 2 can be ON at a time.  
 Only one of the switches 3 ... 7 can be ON at a time.

	OFF	ON	Selection
Channel 3	1		Current output selection, ON=Current output selected
	2		Voltage output selection, ON=Voltage output selected
	3		0...20 mA selection, ON= 0...20 mA selected
	4		4... 20 mA selection, ON= 4... 20 mA selected
	5		0...1 V selection, ON=0...1 V selected
	6		0...5 V selection, ON=0...5 V selected
	7		0...10 V selection, ON= 0...10 V selected.
	8		For service use only, keep always in OFF position.

0508-029

**Figure 31 Third Analog Output Selection**

8. Connect the power.
9. Select the quantity and scale the channel via the serial line or display/keypad, see section Analog Output Quantities on page 117. For testing the analog output, see Section Analog Output Tests on page 119. For fault indication setting, see section Analog Output Fault Indication Setting on page 120.



## Relays

MMT330 can be equipped with one or two configurable relay modules. Each module contains two configurable relays. See the contact ratings in section Technical Specifications of Optional Modules on page 162.

### Installation and Wiring

1. Disconnect the power and open the transmitter cover. In case the relay-module is installed in the factory, continue with step 5.
2. To attach the module fasten the relay module to the bottom of the housing with four screws. See the position in Figure 2 on page 21.
3. When the mains power is in use attach the grounding wire to the grounding terminal.
4. Connect the flat cable between the relay module and the **MODULE 1** or **MODULE 2** pins of the motherboard.
5. Take out the protective plug from the cable gland and thread the relay wires.
6. Connect the wires to the screw terminals: NO, C, and NC.

**CAUTION**

For installations in the USA: If your transmitter has both the relay module and a LAN or WLAN module, the maximum voltage you are allowed to connect to the relay module is 50 V.

### Selecting the Activation State of the Relay

The middlemost C terminal and either one of the terminals NO/NC must be connected. The polarity can be freely selected.

NO	Normally open
C	Common relay
NC	Normally closed

Relay NOT activated:	C and NC outputs are closed, NO is open
Relay IS activated:	C and NO outputs are closed, NC is open.

Connect the power and close the cover.

**NOTE**

For instructions on how to operate the relay (for example, selecting quantity for the relay output and setting the relay setpoints), see section Operation of Relays on page 121.

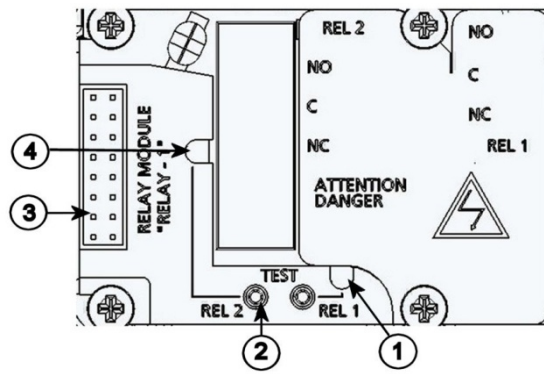

0503-037

**Figure 32 Relay Module**

The following numbers refer to Figure 32 above:

- 1 = Indication led for the relay 1 or 3
- 2 = Relay test buttons
- 3 = Flat cable pins
- 4 = Indication led for relay 2 or 4

**WARNING** The relay module may contain dangerous voltages even if the transmitter power has been disconnected. Before opening the transmitter you must switch off **both** the transmitter **and** the voltage connected to the relay terminals.

**WARNING** Do not connect the mains power to relay unit without grounding the transmitter.

## RS-422/485 Interface

The RS-422/485 interface enables communication between an RS-485 network and the MMT330 transmitter. The RS-485 interface is isolated and offers a maximum communications rate of 115 200 bits/s. (For maximum bus length of 1 km, use bit rate 19200 b/s or less.)

When selecting an RS-232 to RS-485 converter for the network, avoid self-powered converters, as they do not necessarily support the needed power consumption.

**NOTE** RS-232 User Port on MMT330 main board cannot be used and connected when RS-485 module is connected. Service port operates normally.

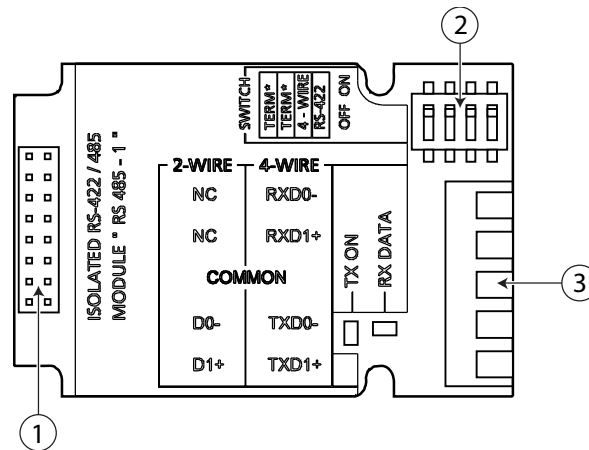

1102-023

**Figure 33 RS-422/485 Module**

The following numbers refer to Figure 33:

- 1 = Flat cable pins
- 2 = Selection switches
- 3 = Screw terminals for wiring

## NOTE

The data lines on earlier versions of the RS-422/485 module are marked A and B instead of D1+ and D0-. When the line is idle, D1+ has positive voltage compared to D0-.

When connecting the module, be prepared to swap the D1+ and D0- wires if you have a communication problem.

## Installation and Wiring

1. Disconnect the power. In case the RS-422/485 module is installed in the factory, continue with the item 4.
2. To attach the module, open the transmitter cover and fasten the RS-422/485 module to the bottom of the housing with four screws.
3. Connect the flat cable between the RS-422/485 module and the motherboard's pins **MODULE1 (Communications)**.
4. Pull the network wirings through the cable gland.
5. Connect the twisted pair wires (1 or 2 pairs) to the screw terminals as presented in Table 6 on page 58:

**Table 6 Connecting the Twisted Pair Wires to the Screw Terminals**

Screw Terminal	Data line (2-wire RS-485)	Data line (4-wire RS-422/485)
1	(not connected)	Rx D0-
2	(not connected)	Rx D1+
3	Common	Common
4	D0-	Tx D0-
5	D1+	Tx D1+

To avoid problems in the RS-422/485 network, the Common terminal should be wired to the corresponding terminals of the other devices.

6. If you use RS-422 or RS-485 to connect just one MMT330 to a master computer, enable the internal termination of MMT330 by switching switches 1 and 2 ON. Make sure that the master's end of the line is also terminated (by using master's internal termination or with a separate terminator).

If you are connecting many transmitters to the same RS-485 bus, make sure that switches 1 and 2 are OFF and terminate the bus with separate terminators at both ends. This allows removing any transmitter without blocking the bus operation.

**NOTE**

If you use the internal termination of the transmitter at the end of the RS-485 bus (instead of using separate terminators) removing that transmitter will block the bus operation.

7. Use the bus type (4-wire/2-wire) to select the selection switch 3.

In 4-wire mode RS-485 master sends data to the MMT330 through terminals Rx D1+ and Rx D0- and receives data from MMT330 through terminals Tx D1+ and Tx D0-.

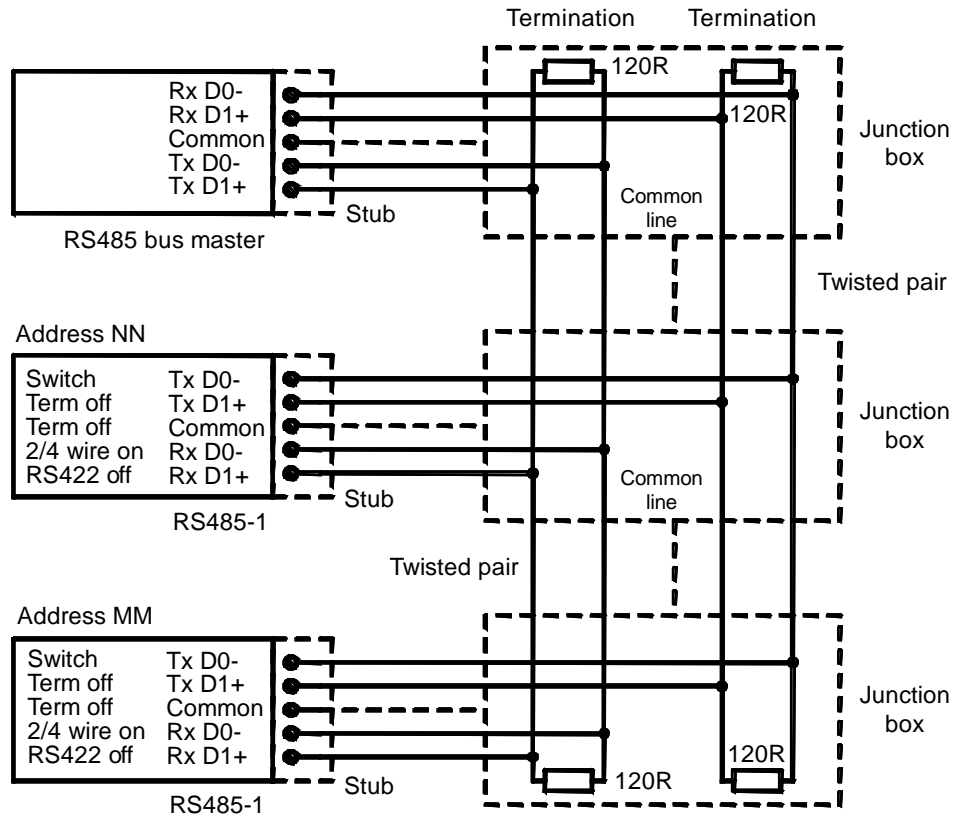

Baud > 19.2K Stub < 10ft, 3m  
 Baud > 112K Stub < 1ft, 0.3m

Termination Termination

1102-028

**Figure 34 4-Wire RS-485 Bus**

**Table 7 4-Wire (Switch 3: On)**

RS-485 master	Data	MMT330
Tx D1+	→	Rx D1+
Tx D0-	→	Rx D0-
Rx D1+	←	Tx D1+
Rx D0-	←	Tx D0-

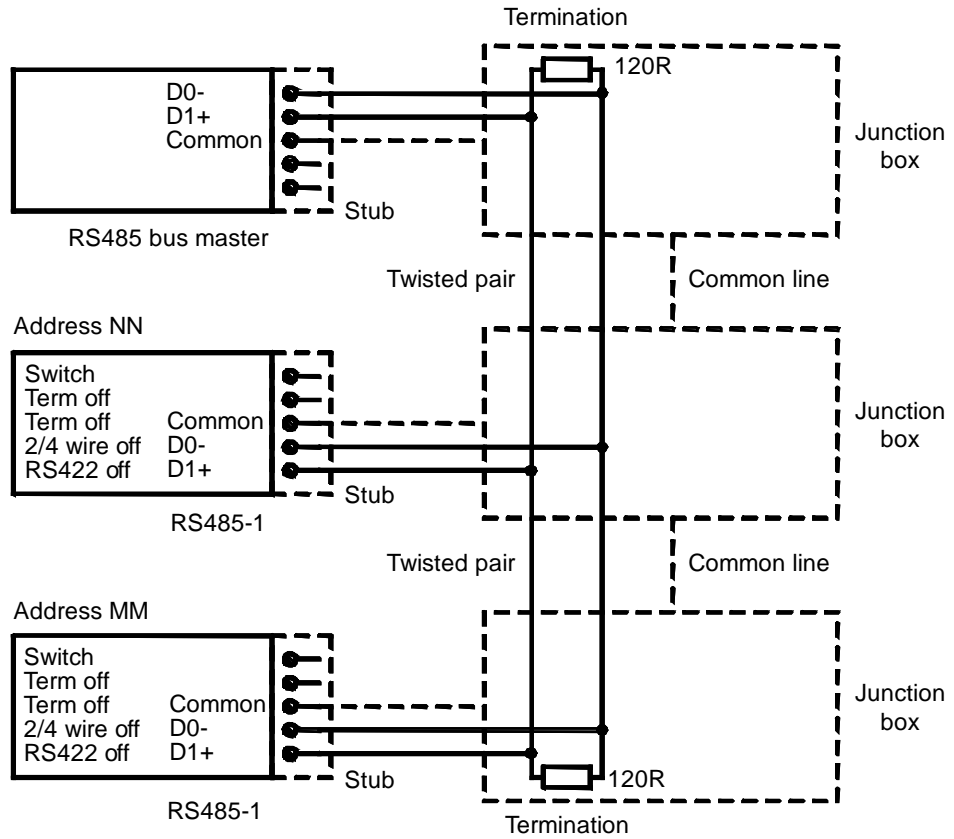

1102-027

**Figure 35 2-Wire RS-485 Bus**

**Table 8 2-Wire (Switch 3: Off)**

RS-485 master	Data	MMT330
D1+	↔	D1+
D0-	↔	D0-

8. When operating in communication mode RS-422, set both switches 3 and 4 to ON position (4-wire wiring is required for RS-422 mode).
9. Connect the power and close the cover.

## LAN Interface

The optional LAN interface enables an Ethernet connection to the transmitter. The user can establish a virtual terminal session using a Telnet client program such as PuTTY or by using Modbus TCP protocol. When the LAN interface is in use, serial communication using the RS-232 User Port is disabled.

The LAN interface module must be installed at the factory (when ordering the transmitter), or by a Vaisala Service Center. Once installed, the module is automatically used by the transmitter. The physical connection to the network is made to the RJ45 connector on the LAN interface module, using a standard twisted pair Ethernet cable (10/100Base-T). Transmitters with the optional LAN interface are delivered pre-installed with a suitable cable and cable gland.

The LAN interface can use both static and dynamic network settings. If the interface is configured to use dynamic settings, the network where the LAN interface is connected must have a DHCP server that provides the settings.

The network configuration can be done using the optional display and keypad, or by using the service port. For instructions, see section LAN Communication on page 82. The LAN interface also provides a web configuration interface, which you can access by entering the IP address of the LAN interface in the address field of a web browser. See section Web Configuration for LAN and WLAN on page 89.

### CAUTION

The LAN interface is designed to be used in trusted network environments (trusted corporate LAN or VPN-based connection over internet). Avoid connecting the transmitter directly to a public network because the device can be attacked by a malicious user through the network.

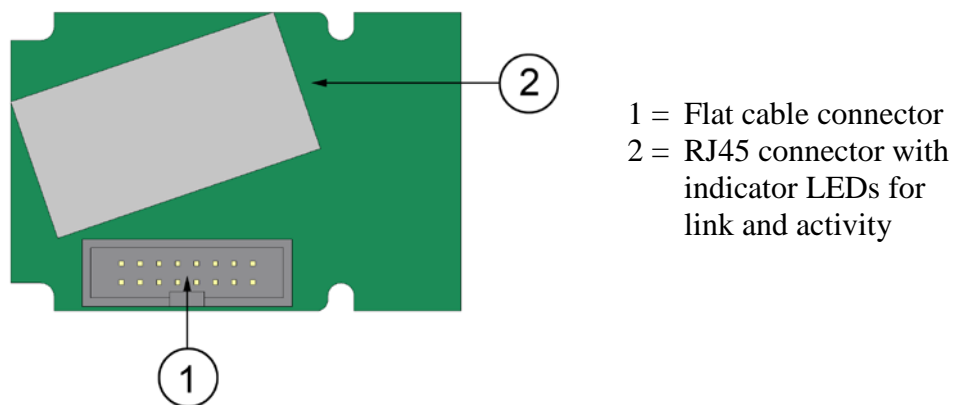

0709-003

**Figure 36** LAN Interface Module

## WLAN Interface

The optional WLAN interface enables a wireless Ethernet connection (IEEE 802.11b) to the transmitter. The user can establish a virtual terminal session using a Telnet client program such as PuTTY or by using Modbus TCP protocol. When the WLAN interface is in use, serial communication using the RS-232 User Port is disabled.

The interface supports Wired Equivalent Privacy (WEP) and Wi-Fi Protected Access (WPA, WPA2). For WEP, 64 and 128 bit encryption is supported, with open system or shared key authentication. WPA is used in the Pre-Shared Key (PSK) mode, with either TKIP or CCMP (also known as AES) encryption.

Similarly to the LAN interface, the WLAN interface can use both static and dynamic network settings. If the interface is configured to use dynamic settings, the network where the WLAN interface is connected must have a DHCP server that provides the settings.

The WLAN interface also provides a web configuration interface, which you can access by entering the IP address of the WLAN interface in the address field of a web browser. See section Web Configuration for LAN and WLAN on page 89.

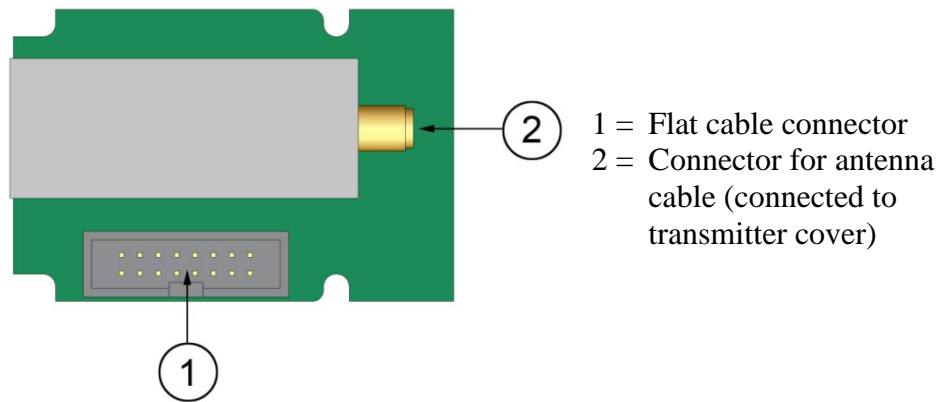

**Figure 37** WLAN Interface Module

**CAUTION**

The WLAN interface is designed to be used in trusted network environments (trusted corporate LAN or VPN-based connection over internet). Avoid connecting the transmitter directly to a public network because the device can be attacked by a malicious user through the network.



**NOTE**

The default country setting for the WLAN interface is United States, which limits the operation to WLAN channels 1 ... 11. To enable additional channels (12 ... 14), you can change the country setting using the web configuration interface.

## Attaching the WLAN Antenna

The WLAN interface module must be installed at the factory (when ordering the transmitter), or by a Vaisala Service Center. Before taking the transmitter into use, you must attach the antenna of the WLAN interface into the RP-SMA connector on the transmitter cover. The location of the antenna is shown in Figure 74 on page 167.

## Data Logger Module

The optional data logger module extends the data storage for the measurement data. When the data logger is present, this storage is automatically used by the transmitter. The stored data can be browsed using the optional display module, and accessed through the serial connections. See sections Graphic History on page 68 and Data Recording on page 111.

The data logger module contains non-volatile flash memory providing 4 years and 5 months of storage for 4 parameters at a 10-second sampling interval. When the memory is full, the data recording will not stop. Instead, the oldest data is overwritten. For each parameter and observation period, the module stores the minimum and maximum values during the interval, as well a data trend value that is averaged from samples taken during the interval (see Table 9 on page 63).

**Table 9 Observation Periods and Resolution**

Observation Period	Period for Trend/Max/Min Calculations (Resolution)
20 minutes	10 seconds
3 hours	90 seconds
1 day	12 minutes
10 days	2 hours
2 months	12 hours
1 year	3 days
4 years	12 days

The quantities that are logged are the same that have been selected for measurement using the display/keypad or the serial line. When taking the transmitter into use, verify that the desired quantities are selected. If you change the quantities later, the transmitter will start logging the new quantities, and stop logging the quantities that are no longer selected. Changing the quantities does not delete any measurement data that is

already in memory. However, the data of any removed quantity cannot be accessed unless the quantity is re-activated first.

The data logger module has a real time clock with a battery back-up. The clock has been set to the Coordinated Universal Time (UTC) at the factory, and its time cannot be set by the user. The data that is stored in the logger's memory is timestamped using the logger's clock.

When date and time are set on the transmitter, they are stored to the transmitter's memory as an offset from the time on the logger's clock. When browsing the stored data, the time offset is applied to the timestamps shown in the graphical history, and data outputted from the serial port. The timestamps in the data logger's memory remain as they were originally stored.

You can compensate for the clock drift (less than  $\pm 2$  min/year) by setting the time on the transmitter. This updates the time offset used on the display and the serial port. You can set the time by using the keypad/display or the serial commands.

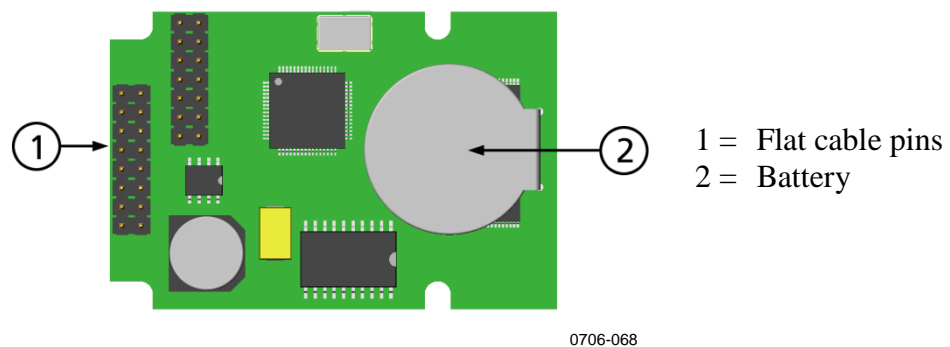

**Figure 38 Data Logger Module**

After a reset or a power up, it will usually take at least 10 seconds before the data logger module is initialized. The instrument will not start up before the data logger module is ready.

The indicator LED on the module will blink green during normal operation. If the LED is lit in red color, there is a problem with the module. The transmitter will also indicate the problem by activating the "Internal error on add-on module" error. If the module is not operating correctly, the transmitter must be sent to Vaisala for maintenance.

The data logger module must be installed at the factory (when ordering the transmitter), or by a Vaisala Service Center. Once installed, the module is automatically used by the transmitter. When the module requires a new battery, the transmitter must be sent to Vaisala for maintenance.

## 8-Pin Connector

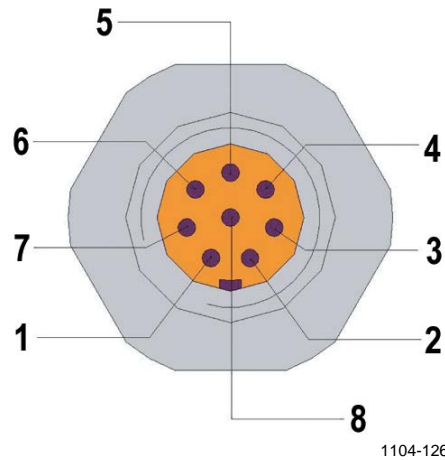

**Figure 39** Pinout of the Optional 8-Pin Connector

**Table 10** Wiring of the Optional 8-Pin Connector

Pin	Wire	Serial Signal		Analog Signal
		RS-232 (EIA-232)	RS-485 (EIA-485)	
1	White	Data out TX	D1+	-
2	Brown	(Serial GND)	(Serial GND)	Signal GND (for both channels)
3	Green	-	-	Ch 2+
4	Yellow	-	-	Ch 1 +
5	Grey	Supply -	Supply -	Supply -
6	Pink	Supply +	Supply +	Supply +
7	Blue	Data in RX	D0-	-
8	Shield/Red	Cable shield	Cable shield	Cable shield

This page intentionally left blank.

## CHAPTER 4

# OPERATION

This chapter contains information that is needed to operate MMT330.

## Getting Started

Within a few seconds after power-up the led on the cover of the transmitter is lit continuously indicating normal operation. If the data logger module is installed, the startup may take up to 18 seconds.

When using the optional display and turning the transmitter on the first time, the language selection menu window opens. Select the language with ▼▲ arrow buttons and press the **SELECT** button (the left-hand  button).

## Display/Keypad (Optional)

### Basic Display

Display shows you the measurement values of the selected quantities in the selected units. You can select 1 ... 3 quantities for the numerical basic display (see section Changing Quantities and Units on page 99.)

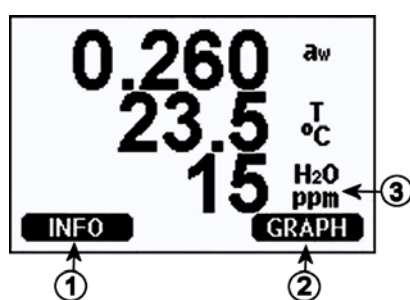

**Figure 40 Basic Display**

The following numbers refer to Figure 40 above:

- 1 = **INFO** shortcut button; see section Device Information on page 104.
- 2 = **GRAPH** shortcut button; see section Graphic History on page 68.
- 3 = Quantities selected for display

**NOTE** From any view, even in the absence of an **EXIT** button, a four-second press on the right-hand function button takes you directly to the basic display.

## Graphic History

The graphical display shows the data trend or min/max graph of the selected quantities, one at a time. The graph is updated automatically while measuring.

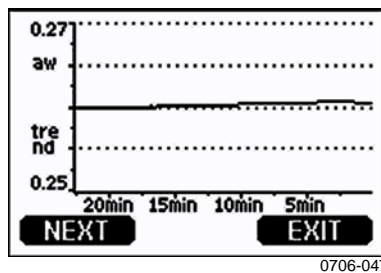

**Figure 41** Graphical Display

**Trend graph:** Shows you a curve of average values. Each value is a calculated average over a period. See Table 11 on page 68.

**Max/min graph:** Shows you the minimum and maximum values in a form of curve. Each point shows the absolute minimum and maximum observed during the time period represented by the data point. See Table 11 on page 68.

**Table 11** Periods for Trend and Max/Min Calculations

Observation Period	Period for Trend/Max/Min Calculations (Resolution)
20 minutes	10 seconds
3 hours	90 seconds
1 day	12 minutes
10 days	2 hours
2 months	12 hours
1 year	3 days
4 year*	12 days

\* Shows the maximum logging period of the data logger module (available when data logger module is installed)

Use the following functions in the graphical display:

- Press the **NEXT** button to change between the trend graph and max/min graph for the quantities selected for display.
- Press the **EXIT** button to return to the basic display.
- Press the **▼ ▲** arrow buttons to zoom in and out in the graph window.

- Press the ◀▶ arrow buttons move the cursor (vertical bar) along the time axis. The cursor mode allows you to observe individual measuring points. The numerical value at the cursor position is shown at the left upper corner. The right upper corner shows the time from the present to the chosen moment (without the logger module), or the date and time at the cursor position (when the logger module is installed).
- If the optional data logger module is installed, you can scroll the cursor off the screen to move to a new point on the time axis. The new date will be displayed, and the cursor will be centered at the date where the cursor scrolled off the screen.

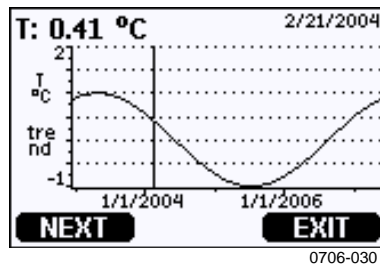

**Figure 42 Graphical Display with Data Logger**

If the data logger module is installed, you can move quickly on the time axis: zoom out, move the cursor, and zoom back in.

The time that is shown below the graph is adjusted with the current time offset of the transmitter. If you change the transmitter's date and time setting, the displayed timestamps in the history graph change accordingly. For an explanation of the effect of changing the date and time manually, see section Data Logger Module on page 63.

**Table 12 Graph Information Messages in Cursor Mode**

Message	Interpretation
Power outage	Power failure (marked also with dashed vertical line)
No data	Quantity has not been selected for the display
System error	General device or power supply problem
T meas. error	Temperature measurement/sensor failure
RH meas. error	Humidity measurement/sensor failure
Adj. mode active	Adjustment mode active (data recorded in the adjustment mode is not displayed)

A question mark after time tells you that at least one power failure (dashed vertical line) has occurred after the chosen moment. In this case, the exact time difference between the present and the cursor position is not exactly known. If the data logger module is installed, the time is known and the question marks are not present.

## Menus and Navigation

You can change settings and select functions in the menus.

1. Open the **Main Menu** by pressing any of the ▼ ▲ ◀ ▶ arrow buttons in the basic (numeric) display mode.
2. Move in the menus by using the ▲ ▼ arrow buttons.
3. Open a submenu with ▶ button.
4. Press ◀ to return to the previous level.
5. Function button **EXIT** returns you back to the basic display.

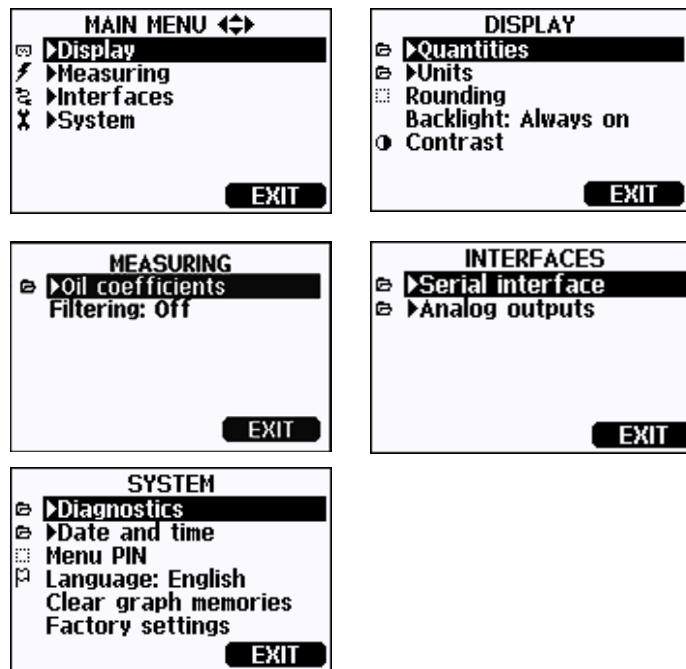













0706-208, 0706-048

**Figure 43** Main Menus

Some menu items, such as **Date and time** in the **System** menu, are only shown if supported by the transmitter and the installed options.







## Changing the Language

1. Go back to the basic display by keeping the right-hand  button pressed for four seconds.
2. Open the **Main menu** by pressing any of the     buttons.
3. Scroll to the **System** menu option, and press the  button. The menu option is indicated with the wrench  symbol.
4. Scroll to the **Language** menu option, and press the left-hand  button. The menu option is indicated with the flag  symbol.
5. Select the language with the   buttons, and confirm the selection by pressing the left-hand  button.
6. Press the right-hand  button to exit to the basic display.





## Rounding Setting

Round off one decimal by using the Rounding function . The default setting is rounding on. Rounding has no effect on quantities without decimals.

1. Open the **Main Menu** by pressing any of the     arrow buttons.
2. Select **Display** and confirm by pressing the  arrow button.
3. Select **Rounding** and press **ON/OFF** button.
4. Press **EXIT** to return to the basic display.

## Display Backlight Setting

As a default the display backlight is always on. In the automatic mode the backlight stays on for 30 seconds from the last press of any button. When pressing any button, the light turns on again.

1. Open the **Main Menu** by pressing any of the     arrow buttons.
2. Select **Display**, press the  arrow button.
3. Select **Backlight**, press the **CHANGE** button.
4. Select **On/Off/Automatic**, press the **SELECT** button.
5. Press **EXIT** to return to the basic display.

## Display Contrast Setting

Display contrast is automatically adjusted based on the ambient temperature. However, depending on the installation location and viewing direction, it may be necessary to fine-tune the contrast manually.

### Using Display/Keypad

1. Open the **Main Menu** by pressing any of the ▲▼◀▶ arrow buttons.
2. Select **Display**, press the ▶ arrow button.
3. Select **Contrast**, press the **ADJUST** button.
4. Adjust the contrast by pressing the ◀▶ arrow buttons.
5. Press **OK** and **EXIT** to return to the basic display.

### Using Serial Line

Use the serial line command **CON** to view or set the display contrast.

**CON [xxx]<cr>**

where

xxx = Contrast value for display. Recommended range -9 ... 9, default 0. Negative values make screen lighter, positive values make it darker.

Example (view current contrast setting):

```
>con
Contrast      : 0
>
```

Example (set contrast to 5):

```
>con 5
Contrast      : 5
>
```

## Keypad Lock (Keyguard)

This function locks the keypad and prevents unintentional key presses.

1. Keep pressing the left-hand function button for 4 seconds to lock the keypad (at any display).
2. To unlock the keypad, press the **OPEN** button for 4 seconds.

## Menu PIN Lock

You can prevent unauthorized changes of the device settings by activating the menu PIN lock. When this function is activated, the basic display, graphical view, and device information displays are available, but access to the menus is locked. The key symbol indicates the activation of this feature.

1. Open the **Main Menu** by pressing any of the ▲ ▼ ◀ ▶ arrow buttons.
2. Select **System**, press the ▶ arrow button.
3. Select **Menu PIN**, press the ON button.
4. Enter a PIN code by using the ◀ ▶ arrow buttons. Press **OK** to confirm the setting. Now the PIN lock is on and a key symbol is shown in a display.
5. Press **EXIT** to return to the basic display. Returning to the menu is possible only by entering the correct PIN code.

When you want to turn off the PIN lock, go to the menu by giving the PIN code and select **System, Menu PIN**, press **OFF** button.

In case you have forgotten the PIN code, open the transmitter cover and press the **ADJ** button once. Wait for a few seconds and the adjustment menu opens. Select **Clear menu PIN**, press  **CLEAR**.

### NOTE

You can also disable the keypad completely with serial command **LOCK**. See section Locking Menu/Keypad Using Serial Line on page 107.

## Factory Settings

Use the display/keypad to restore the factory settings. This operation does not affect the adjustments. Only settings available in the menus are restored.

1. Press any of the arrow buttons to open the **Main Menu**.
2. Select **System** by pressing the ▶ arrow button.
3. Select **Factory settings** and press the **REVERT** button to confirm your selection. Press the **YES** button to reset all settings to the factory defaults.

See section General Settings on page 99 for a description of the other menu options.

## Display Alarms

The Display Alarm feature provides two independently configurable alarms for transmitters with the display/keypad option. Each alarm tracks a selected quantity, with freely configurable limit values. Each alarm also has a configurable hysteresis value to prevent unnecessary triggering when the measurement fluctuates around an alarm limit. The alarms can be configured for any quantity supported by the transmitter. The configuration of the Display Alarms can only be done using the display/keypad option.

You can have the alarm activate inside or outside the specified range by setting the limits correctly:

- To have the alarm activate when the measured quantity is outside the specified range, set the **Act. above** limit higher than the **Act. below** limit.
- To have the alarm activate when the measured quantity is inside the range, set the **Act. above** limit lower than the **Act. below** limit.

The alarm limits are shown on the graph display as thicker dotted lines. When a display alarm is activated, the automatic scaling of the graph display always keeps the limits in view.

When an alarm is activated, an alarm note is displayed on the display, and the lights of the display will blink. If the data logger module is installed, the alarm note includes the time and date of the alarm.



0802-041

**Figure 44** Display Alarm Active

Multiple alarms can be active at the same time; the alarm that was triggered first will be shown on the display. The next active alarm is revealed when the currently shown alarm is acknowledged by pressing the **OK** button.

Activated alarms are only shown on the screen; there are no alarm messages output to the serial line. After an alarm has been acknowledged, you must refer to the data graphs to see when the measured quantities have exceeded the limits. You may use the optional

relay outputs as alarm outputs by configuring them separately; see section Setting Relay Outputs on page 125.

## Configuring a Display Alarm

1. Enter the **Main Menu** by pressing an arrow key on the keypad.
2. Use the arrow keys to select **Display**, followed by **Alarms**, to open the **Display Alarms** menu. The Display Alarms menu shows the currently enabled and disabled alarms.



0802-069

**Figure 45** Display Alarms

3. Use the arrow keys to select an alarm to configure. The alarm editing page opens.

### NOTE

Changes you do on the alarm editing page will take effect immediately, and may cause an alarm to appear on the screen.

4. To select a quantity for the alarm, press the **Change** button and select the quantity from the list.
5. To modify or remove the alarm limit values, move the selection over the **Act. above** or **Act. below** field and press the **Set** button. You will be prompted to **Modify** or **Remove** the value.

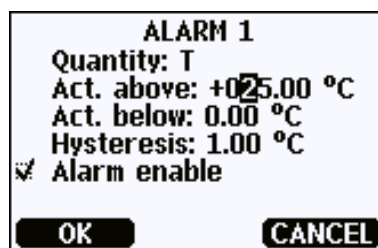

0802-070

**Figure 46** Modifying an Alarm Limit

When modifying the value, use the arrow up and down buttons to change the value under the cursor. Left and right arrow buttons move the cursor. Select the **OK** button to accept the modified value, or **Cancel** to undo the modification.

6. Set a suitable **Hysteresis** value to prevent the alarm from being triggered unnecessarily by small measurement changes that pass the alarm limit repeatedly.
7. Set or clear the **Alarm enable** checkbox to enable or disable the alarm.
8. Press the **Exit** button to leave the alarm configuration screen and return to the basic view.

## Using Serial Line

Use the serial line command **ALSEL** to view or set the display alarms.

**ALSEL [quantity1 quantity2]<cr>**

where

quantity1 = Quantity for display alarm 1. You can set any quantity available on your transmitter; see Table 3 on page 19 and Table 4 on page 19. In addition to quantities, you can also select the following:

FAULT – Alarm for device errors

ONLINE – Alarm for sensor operations that freeze the measurement output (for example, chemical purge).

quantity2 = Quantity for display alarm 2. Options are the same as for quantity1.

Example (view current display alarm settings):

```
>alsel ?
All aw   above: 0.50  ?
All aw   below: - ?
All aw   hyst : 0.10  ?
All aw   enabl: ON ?
Al2 T    above: 0.00 'C ?
Al2 T    below: 0.00 'C ?
Al2 T    hyst : 0.00 'C ?
Al2 T    enabl: OFF ?
Warning! One or more alarms disabled.
>
```

**Table 13 ALSEL Parameters**

<b>Name</b>	<b>Description</b>
above	If specified, the alarm goes off when the quantity value rises above the exact value of this setpoint. However, if above < below, the alarm goes off at (above + hyst) and (below – hyst) instead. Cannot be set for fault and online alarms.
below	If specified, the alarm goes off when the quantity value decreases below the exact value of this setpoint. However, if above < below, the alarm goes off at (above + hyst) and (below – hyst) instead. Cannot be set for fault and online alarms.
hyst	Distance from setpoint amount of extra retractment needed in order to regenerate alarm on the next crossing of the setpoint. Cannot be set for fault and online alarms.
enabl	Enable (ON) or disable (OFF) the display alarm.

Example (set  $a_w$  and T as display alarm quantities and configure the alarms as prompted):

```
>alsel aw t
A11 aw   above: 0.50 ? 0.6
A11 aw   below: - ?
A11 aw   hyst : 0.10 ?
A11 aw   enabl: ON ?
A12 T    above: - 'C ?
A12 T    below: - 'C ? 0
A12 T    hyst : 0.00 'C ? 1
A12 T    enabl: OFF ? ON
>
```

## MI70 Link Program for Data Handling

MI70 Link is a support program that enables you to handle the measurement data of your Vaisala transmitter using a Windows PC. Using the MI70 Link you can, for example:

- Monitor the transmitter's measurement readings directly using the real-time window function.
- Transfer recorded data from the main transmitter memory in numeric or graphical format, for further use in a spreadsheet program (such as Microsoft Excel) or virtually any other application. Note that the maximum amount of data points that can be downloaded in one transfer is 65000.

To use the MI70 Link program, you must connect your Windows PC to the service port of the transmitter with a serial or USB cable. The MI70 Link program, and the optional connection cables, are available from Vaisala. See section Spare Parts and Accessories on page 164.

Follow the steps below to connect your transmitter to the MI70 Link program using the serial interface:

1. Connect your PC to the service port of the transmitter. Refer to section Service Port Connection on page 81.
2. Check that the MMT330 is powered.
3. Start the MI70 Link program.
4. Start using the program. There is usually no need to select a COM port manually, the MI70 Link software can detect it automatically.

**NOTE**

For instructions on using MI70 Link, see the program's online help.



## Serial Line Communication

Connect the serial interface by using either the user port or the service port.

For permanent interfacing to host system, use the user port. You can change the serial settings and operate in RUN, STOP, SEND, POLL, and MODBUS modes.

For temporary connections use the service port. Service port is always available with fixed serial settings.

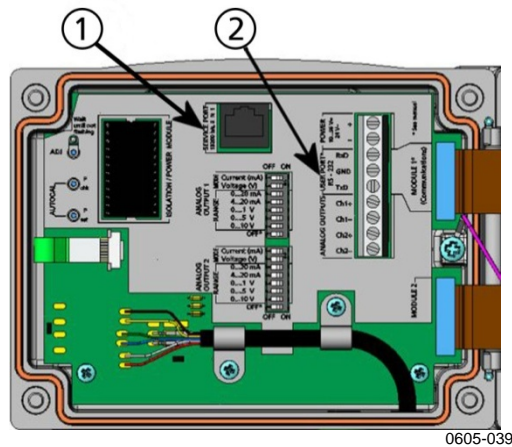

**Figure 47 Service Port Connector and User Port Terminal on Motherboard**

The following numbers refer to Figure 47 above:

- 1 = Service port connector
- 2 = User port terminals

## User Port Connection

Use suitable serial cable between the user port RxD, GND and TxD screw terminals and the PC serial port, see Figure 48 below.

**Table 14 Default Serial Communication Settings for the User Port**

Parameter	Value
Bauds	4800
Parity	Even
Data bits	7
Stop bits	1
Flow control	None

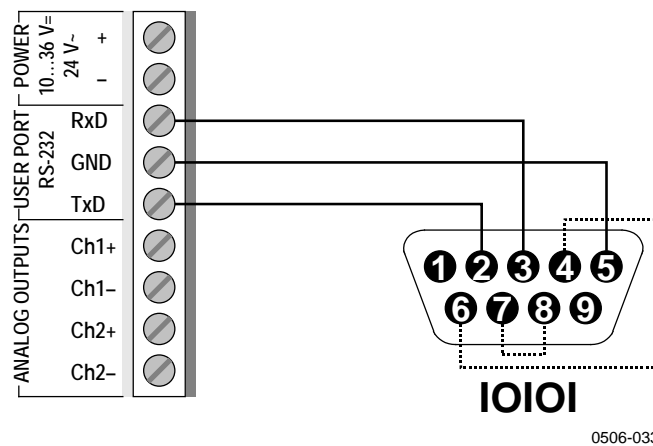

**Figure 48 Connection Example between PC Serial Port and User Port**

Connections to pins 4,6,7 and 8 on PC serial port are required only if you are using software requiring hardware handshaking.

## User Port Operating Modes

When the transmitter is powered up, it will behave according to its configured operating mode:

- In STOP mode, the transmitter outputs the software version and the command prompt (if echo is on).
- In RUN mode a measurement output starts immediately.
- In SEND mode one measurement message is printed and command prompt is displayed (if echo is on).
- In POLL or MODBUS mode, the transmitter does not output anything after power-up.

For a description of the modes, see section SMODE on page 109.

**NOTE**

RS-232 User Port cannot be used when a communication module (LAN, WLAN, or RS-422/485 interface) has been installed.

## Service Port Connection

### Connection Cables

To connect to the service port, you need a suitable cable with an RJ45 connector. Depending on the connections of your PC, you can either use the Serial Connection Cable (optional accessory 19446ZZ) or the USB-RJ45 Serial Connection Cable (optional accessory 219685). The USB cable enables you to connect the transmitter to a PC via a standard type A USB port. Note that the USB cable does not enable high speed data transfer, since the bit rate is limited by the serial interface of the service port.

### Installing the Driver for the USB Cable

Before taking the USB cable into use, you must install the provided USB driver on your PC. When installing the driver, you must acknowledge any security prompts that may appear.

1. Check that the USB cable is not connected. Disconnect the cable if you have already connected it.
2. Insert the media that came with the cable, or download the latest driver from <http://www.vaisala.com/software>.
3. Execute the USB driver installation program (setup.exe), and accept the installation defaults.
4. After the driver has been installed, connect the USB service cable to a USB port on your PC. Windows will detect the new device, and use the driver automatically.
5. The installation has reserved a COM port for the cable. Verify the port number, and the status of the cable, using the **Vaisala USB Instrument Finder** program that has been installed in the Windows Start menu.

Windows will recognize each individual cable as a different device, and reserve a new COM port. Remember to use the correct port in the settings of your terminal program.

## Using the Service Port

1. Open the screws on the transmitter cover, and open the cover.
2. Connect the desired cable (serial interface cable or USB cable) to your PC and the service port connector on the transmitter. For the location of the service port, refer to Figure 47 on page 79.
3. Open a terminal program and set the communication settings as follows:

**Table 15**      **Communication Settings for the Service Port**

Parameter	Value
Bauds	19200
Parity	None
Data bits	8
Stop bits	1
Flow control	None

For a detailed explanation of using a terminal program, see section Terminal Program Settings on page 90.

4. Power-up the MMT330.

## LAN Communication

To enable LAN communication, a LAN or WLAN interface must be physically connected to the network, and the networking settings must be suitable for your network. For a description of interfaces, see sections LAN Interface on page 61 and WLAN Interface on page 62.

The LAN and WLAN interfaces both operate by accessing the serial interface (User Port) of the transmitter. All commands and protocols that are available using the serial interface are available through the LAN and WLAN interfaces; refer to section List of Serial Commands on page 90. For instructions on how to connect using a terminal program, see section Terminal Program Settings on page 90.

## IP Configuration

The IP settings of the LAN and WLAN interfaces are described in Table 16. The current settings can be viewed on the serial line or using the device information display; see section Device Information on page 104.

**Table 16 IP Settings for the LAN and WLAN Interfaces**

Parameter	Description
Automatic configuration (DHCP)	If enabled, the transmitter will retrieve its network settings (including the IP Address) from a server in the network. If disabled, static network settings are used instead.
Web configuration	If enabled, the settings of the interface can be changed using a web browser. The configuration page can be accessed by browsing to the IP address of the transmitter.
IP Address	The four part network ID of the transmitter. Must be set manually if automatic configuration is not used.  Example value: <b>192.168.0.222</b>
Netmask	Used together with the IP address to determine which network the transmitter is a part of. Must be set manually if automatic configuration is not used.  A common netmask is <b>255.255.255.0</b>
Gateway	IP address of the server that enables the transmitter to access other networks. Must be set manually if automatic configuration is not used.  Example value: <b>192.168.0.1</b>
MAC	The MAC address is the unique hardware address of the LAN or WLAN interface. Cannot be changed.

## Using Display/Keypad

You can configure the IP settings of the LAN and WLAN interfaces using the display/keypad as follows:

1. Press any of the arrow buttons to open the **Main Menu**.
2. Press the ► arrow button to select **Interfaces**.
3. Press ► arrow button to select **Network settings**. There will be a delay as the transmitter refreshes the network information.
4. You are now in the **Network Interface** menu. Selecting the **IP configuration** option opens the IP configuration menu.

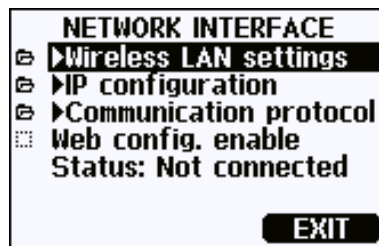

1102-015

**Figure 49 Network Interface Menu**

The **Network Interface** menu also allows you to configure the **Communication Protocol**, enable or disable the **Web configuration** option, or **Disconnect all** users that are currently accessing the LAN or WLAN interface.

5. In the IP configuration menu, select **Automatic configuration (DHCP)**, or enter the **IP address**, **Netmask** and **Gateway** manually. If automatic configuration is enabled, manual configuration cannot be done.

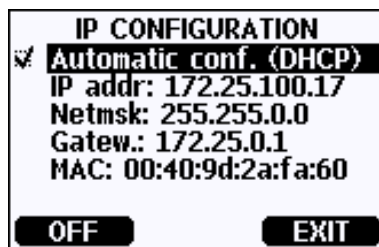

0709-004

**Figure 50 IP Configuration Menu**

To enter a value manually, use the ▲▼ arrow buttons to select the parameter to change, and press **Change**. A cursor will appear in the first digit. Move the cursor using the ◀▶ arrow buttons, and change the value under the cursor using the ▲▼ arrow buttons. Confirm the selection by pressing **OK**.

6. After configuring the desired parameters, press **EXIT** to apply the changes and return to the basic display.

## Using Serial Line

Use the serial line command **NET** to view or set the network settings for the LAN and WLAN interfaces. You can also refresh the network information or disconnect all active connections.

```
NET [REFRESH] [DISCONNECT] [DHCP WEB] [DHCP IP SUBNET GATEWAY WEB]  
<cr>
```

where

<b>REFRESH</b>	=	Updates the network information and displays it
<b>DISCONNECT</b>	=	Disconnects all current sessions
<b>DHCP</b>	=	ON or OFF. Enables or disables the automatic IP configuration.
<b>WEB</b>	=	ON or OFF. Enables or disables the Web Configuration page.
<b>IP</b>	=	The four part network ID of the transmitter. Must be set manually if automatic configuration is not used.
<b>SUBNET</b>	=	Used together with the IP address to determine which network the transmitter is a part of. Must be set manually if automatic configuration is not used.
<b>GATEWAY</b>	=	IP address of the server that enables the transmitter to access other networks. Must be set manually if automatic configuration is not used.

Examples:

```
>net refresh  
OK  
DHCP : OFF  
IP address : 192.168.0.101  
Subnet mask : 255.255.255.0  
Default gateway: 192.168.0.1  
Web config. : OFF  
MAC address : 00:40:9d:2c:d2:05  
Status : Not connected  
>
```

```
>net on off  
DHCP : ON  
IP address : 192.168.0.104  
Subnet mask : 255.255.255.0  
Default gateway: 192.168.0.1  
Web config. : OFF  
MAC address : 00:40:9d:2c:d2:05  
Status : Connected  
OK  
>
```

```

>net off 192.168.0.101 255.255.255.0 192.168.0.1 off
DHCP          : OFF
IP address    : 192.168.0.101
Subnet mask   : 255.255.255.0
Default gateway: 192.168.0.1
Web config.   : OFF
MAC address   : 00:40:9d:2c:d2:05
Status       : Connected
OK
>

```

## Wireless LAN Configuration

The settings of the WLAN interface are described in Table 17. The current settings can be viewed on the serial line or using the device information display; see section Device Information on page 104.

- CCMP encryption is called **AES** in some networking products.
- The WLAN interface supports both WPA and WPA2 (also known as 802.11i) security when either WPA-PSK mode is selected.
- If your WLAN network is using some other security method than listed below, you must set up a temporary WLAN network with any of these settings and then use the web configuration to set WLAN security settings for the actual network. See section Web Configuration for LAN and WLAN on page 89.

**Table 17 Wireless LAN Settings**

Parameter	Description
SSID	The service set identifier (that is, network name) of the wireless network to connect to. 1 ... 32 characters.
Security type	The security type of the wireless network. The options are:  OPEN OPEN/WEP WPA-PSK/TKIP WPA-PSK/CCMP  All other choices except OPEN require a security key; see below.
Security key	The encryption key or passphrase that is used with an encrypted network.



## Using Display/Keypad

You can configure the Wireless LAN settings using the display/keypad as follows:

1. Press any of the arrow buttons to open the **Main Menu**.
2. Press the ► arrow button to select **Interfaces**.
3. Press the ► arrow button to select **Network settings**. There will be a delay as the transmitter refreshes the network information.
4. Press the ► arrow button to select **Wireless LAN settings**.

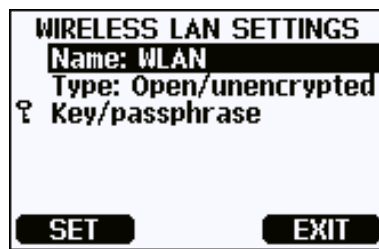

0802-111

**Figure 51** Wireless LAN Settings

5. The **Name** entry on the page shows the SSID of the currently selected wireless network. To change the SSID, press the **SET** button. Use the ▲▼ arrow buttons to change the character under the cursor, and ◀▶ arrow buttons to move the cursor. Press the **OK** button when done.

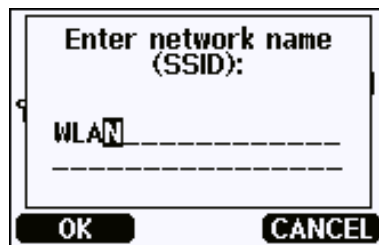

0802-110

**Figure 52** Entering Network SSID

6. To change the currently selected Network type, select the **Type** entry and press the **Change** button. Select the new type from the list and press the **Select** button.

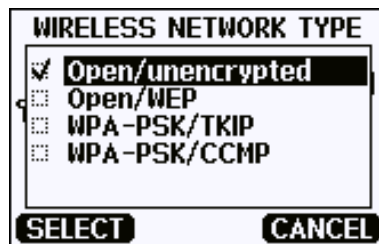

0802-112

**Figure 53** Selecting the Wireless Network Type

7. If you have selected an encrypted network type (WEP or WPA), you must enter the security key to be used. Select the **Key/passphrase** entry and press the **Set** button. Enter the key in the same way as the SSID, and press the **OK** button. With the WEP encryption you must enter the encryption key in hexadecimal (10 hexdecimals for 64-bit encryption or 26 hexdecimals for 128-bit encryption). A WPA key must be 8 ... 63 ASCII characters.
8. After setting the wireless network parameters, press the **Exit** button in the **Wireless LAN Settings** menu. You will be asked to confirm the new settings. Note that when new settings are saved, all currently active WLAN connections are disconnected.

## Using Serial Line

Use the serial line command **WLAN** to view or set the wireless network settings. If you set an encrypted network type, you will be asked to enter the security key. With the WEP encryption you must enter the encryption key in hexadecimal (10 hexdecimals for 64-bit encryption or 26 hexdecimals for 128-bit encryption) or with plain ASCII characters (5 characters for 64-bit encryption or 13 characters for 128-bit encryption). A WPA key must be 8 ... 63 ASCII characters.

**WLAN** [*SSID TYPE*]<cr>

where

SSID           = Network name in 1 ... 32 characters  
TYPE           = Security type of the wireless network. The options are:

OPEN  
OPEN/WEP  
WPA-PSK/TKIP  
WPA-PSK/CCMP

Examples:

```
>wlan ?  
Network SSID    : WLAN-AP  
Type            : OPEN  
>  
  
>wlan accesspoint wpa-psk/kip  
Network SSID    : accesspoint  
Type            : WPA-PSK/TKIP  
WPA-PSK phrase ? thequickbrownfox  
Save changes (Y/N) ? y  
OK  
>
```

## Communication Protocol

When a connection is established via the LAN or WLAN interface, the session has the same communication mode, run interval, poll address and echo settings as the serial port (User Port) session would have.

These settings can be changed using the display/keypad, using the serial line (User Port or Service Port), or on-the-fly during a Telnet session.

The display menu path to the Communication Protocol settings is:  
**Main Menu ► Interfaces ► Network Interface ► Communication Protocol.**

The commands for changing the settings are **SMODE**, **INTV**, **ADDR**, and **ECHO**.

## Web Configuration for LAN and WLAN

The LAN and WLAN interfaces both have a web configuration page that is accessible using a browser. If you have not disabled the page from the network settings, you can access it with a web browser at the IP address of the interface. You can check the currently assigned IP address of the interface from the device information screens (see Device Information on page 104), or from the serial line by issuing the **net ?** command.

When accessing the web configuration page, you must first log in.

Username: **user**  
Password: **vaisala**

The web configuration page provides similar network configuration options as the serial line and the display/keypad. It also has additional options for advanced users. For example, there are more options for securing the wireless network.

If these additional options are used, they will appear as custom configurations when viewed from the serial line or the display/keypad.

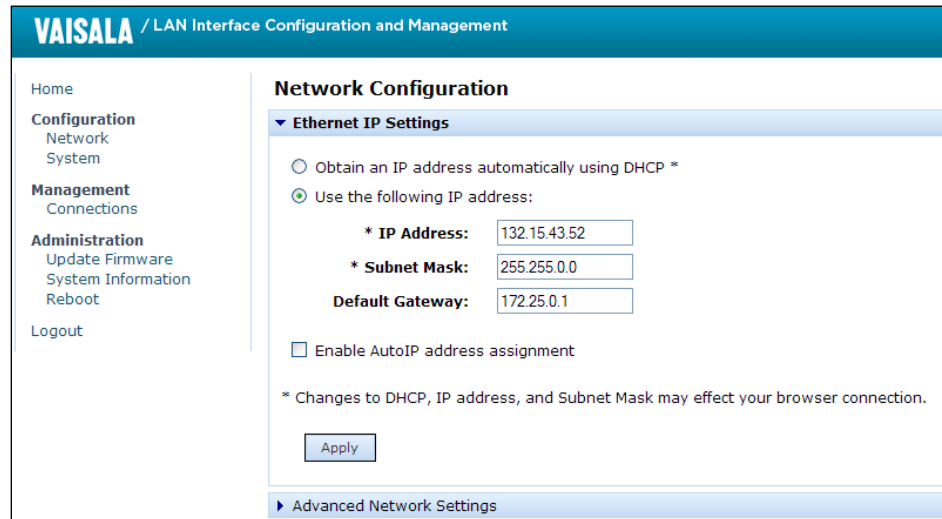

1102-017

**Figure 54** Web Configuration Interface for LAN

## Terminal Program Settings

The instructions below describe how to connect to the MMT330 using the PuTTY terminal application for Windows. Perform the necessary cabling and configuration of the transmitter before following the instructions.

PuTTY is available for download at [www.vaisala.com/software](http://www.vaisala.com/software).

### NOTE

PuTTY cannot be used to access the transmitter through the User Port if the transmitter is configured to use the Modbus protocol. However, you can always use PuTTY to access the transmitter through the Service Port.

## Opening a Serial/USB connection

1. Power up the MMT330 and start the PuTTY application.
2. Select the Serial & USB settings category, and check that the correct COM port is selected in the **Serial or USB line to connect to** field. Change the port if necessary.

If you are using a Vaisala USB cable, you can check the port that it uses by clicking the **USB Finder...** button. This opens the *Vaisala USB Instrument Finder* program that has been installed along with the USB drivers.

3. Check that the other serial/USB line settings are correct for your connection, and change if necessary. The default settings (shown in Figure 55 on page 91) are used by the Service Port of the MMT330.

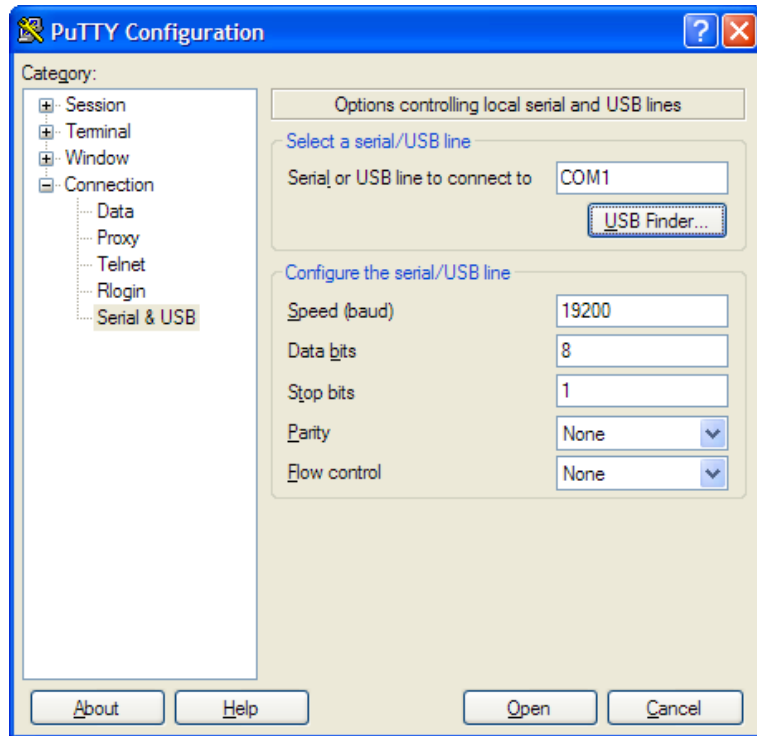

0810-070

**Figure 55** Opening a Serial Connection

4. Click the **Open** button to open the connection window and start using the serial line.

If PuTTY is unable to open the serial port you selected, it will show you an error message instead. If this happens, restart PuTTY and check the settings.

## Opening a Telnet session (LAN/WLAN)

**NOTE**

The instructions below assume that the LAN/WLAN interface on the transmitter is correctly configured and the network connection is already done.

1. Power up the instrument and start the PuTTY application. If your transmitter acquires a network address using DHCP, wait for a minute for this to complete, then verify the address from the transmitter.
2. In the Session window, select the **Telnet** connection type.
3. Enter the IP address of your transmitter in the **Host Name (or IP address)** field. Use the default Telnet port **23**.

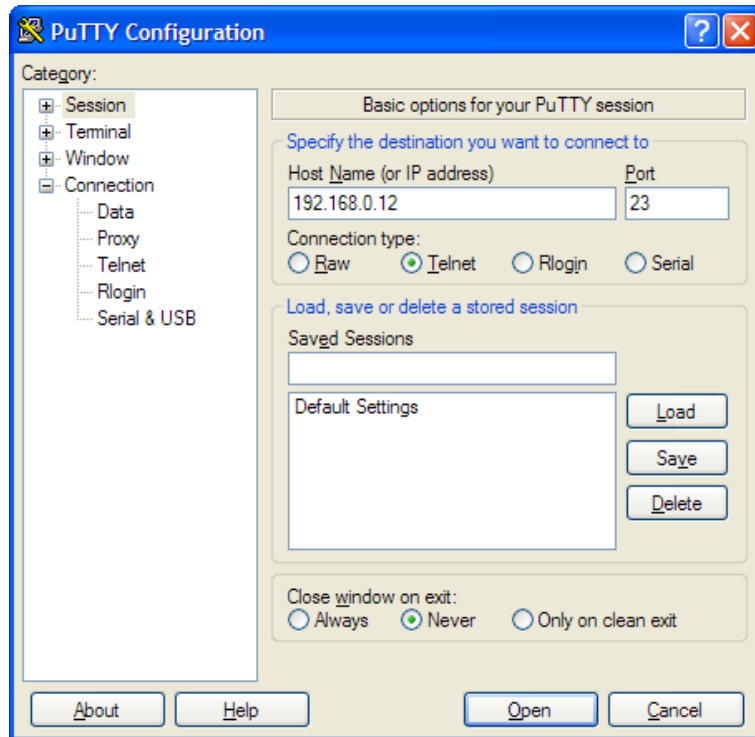

0810-071

**Figure 56** Opening a Telnet Connection

4. Click the **Open** button to open the connection window and start using the Telnet session.

If PuTTY is unable to connect the IP address you entered, it will show you an error message instead. If this happens, check the IP address and the connections, restart PuTTY, and try again.

## List of Serial Commands

All commands can be issued either in uppercase or lowercase. In the command examples, the keyboard input by the user is in **bold** type.

The notation <cr> refers to pressing the carriage return (**Enter**) key on your computer keyboard. Enter a <cr> to clear the command buffer before starting to enter commands.

In the tables below, the **bold** text in the brackets is the default setting.

**Table 18 Measurement Commands**

Command	Description
R	Start the continuous outputting
S	Stop the continuous outputting
INTV [ <b>0</b> ... 255 S/MIN/H]	Set the continuous output interval (for RUN mode)
SEND [ <b>0</b> ... 255]	Output the reading once
DSEND	Output the reading once from all connected transmitters (in STOP or POLL mode)
SMODE [ <b>STOP</b> /SEND/RUN/POLL/ MODBUS]	Set the serial interface mode
SDELAY	View or set user port (RS232 or RS485) answer minimum delay
SERI [baud p d s]	User Port settings (Default: 4800 E 7 1) baud: 300 ... 115200
ADDR [ <b>0</b> ... 255]	Set the transmitter address (for POLL and MODBUS modes)
NET	View or set networking parameters for LAN and WLAN interfaces
WLAN	View or set wireless network parameters for WLAN interface
OPEN [ <b>0</b> ... 255]	Open a temporary connection to a POLL mode device
CLOSE	Close the temporary connection (Back to POLL mode)

**Table 19 Formatting Commands**

Command	Description
FORM	Set the output format of SEND and R commands
TIME	Set the time
DATE	Set the date
FTIME [ON/OFF]	Add time to SEND and R outputs
FDATE [ON/OFF]	Add date to SEND and R outputs
SCOM	Assign a new command name that works like the SEND command
UNIT	Select the metric or non-metric output units

**Table 20 Data Recording Commands**

Command	Description
DIR	Display recorded files
PLAY [0 ... 21] [START END]	Output recorded data file. Start and end times can only be specified if the data logger module is installed. The times must be given in the following format: yyyy-mm-dd hh:mm:ss
DSEL	Select data recording and display quantities.
DELETE	Delete all data files, including the memory of the optional data logger module
UNDELETE	Recover the deleted files that have not been overwritten

**Table 21 Calibration and Adjustment Commands**

Command	Description
CRH	Relative humidity calibration
CT	Temperature calibration
FCRH	Relative humidity calibration after sensor change
CTEXT	Give the text to calibration information field
CDATE	Set the calibration date
ACAL	Analog output calibration

**Table 22 Setting and Testing the Analog Outputs**

Command	Description
AMODE	View the analog output modes
ASEL	Select the parameters for the analog outputs
ITEST	Test the analog outputs
AERR	Change the analog error output values
AOVER [ON/OFF]	Extend analog output range by 10%

**Table 23 Setting and Testing the Relays**

Command	Description
RSEL	Set and view the relays
RTEST	Test the relays



**Table 24 Other Commands**

Command	Description
?	Output information about the device
??	Output information about the device in POLL mode
ALSEL	Set display alarms
CON	Set display contrast
ECHO [ON/OFF]	Turn the serial interface echo ON/OFF
ERRS	List present transmitter errors
FILT	Set the result filtering
FIND	All devices in POLL mode send their addresses
HELP	List the currently available commands
LIGHT	Set the display backlight mode
LOCK	Lock the menu or disable the keypad
MODBUS	View Modbus diagnostic counters
MODS	View information about connected modules
OIL	Set oil-specific parameters for ppm conversion
VERS	Display the software version information

## Getting Measurement Message from Serial Line

### Starting Continuous Outputting

Enter the **R** command to start the continuous output of measurements.

**R**<cr>

Example:

```
>r
aw= 0.261 T= 23.8 'C H2O= 15 ppm
>
```

If a value is too long to fit to the allocated space in the output, or if there is an error in outputting the quantity, the value is displayed with stars '\*’.

You can change the format of the output with the following commands:

- Outputting interval can be changed with the **INTV** command.
- Output message format can be changed with the **FORM** command.

## Stopping Continuous Outputting

Use the **S** command to end the RUN mode. After this command all other commands can be used. You can also press the Esc button or reset the transmitter to stop the outputting.

```
S<cr>
```

See command **SMODE** to change the default (power-up) operation mode.

## Outputting Reading Once

Use the **SEND** command to output the reading once in STOP mode.

```
SEND<cr>
```

The output format depends on which parameters the transmitter can output.

Examples:

```
>send  
RS= 45.1% T= 23.8 'C H2O= 15 ppm  
>
```

## Assign an Alias for the SEND Command

Use the **SCOM** command to assign a new command that works like the **SEND** command. The standard **SEND** command of the transmitter will always function normally whatever the **SCOM** definition may be. Command names are case-insensitive.

```
SCOM<cr>
```

Example (assigning the command **MEASURE** as an alias for the **SEND** command):

```
>scm  
Send command : ? measure  
>measure  
aw= 0.261 T= 23.8 'C H2O= 15 ppm  
>
```

You can remove the **SCOM** definition by pressing **Esc** when entering the command name:

```
>scm  
Send command : measure ? <esc>
```

## Outputting Reading Once From All Transmitters

Use the **DSEND** command to output the reading once from all connected transmitters that are in STOP or POLL modes. In order to avoid data collisions, the transmitters will send their response after a suitable delay. The response includes the transmitters's address, followed by their measurement message.

### NOTE

The total execution time of the **DSEND** command depends on the bit rate of the serial port connection. At slow speeds, it will take a considerable amount of time for devices with large address number to respond. The delay will be the same even if there are no other devices at all.

**DSEND**<cr>

Example (transmitters with addresses 3 and 25 responding):

```
>dsend
  3 RS=  41.2% T= 23.8 'C H2O=  15 ppm
 25 aw=  0.277 T= 23.5 'C H2O=  16 ppm
>
```

## Communicating with a Transmitter in POLL Mode

### OPEN

When all transmitters on the RS-485 bus are in POLL mode the **OPEN** command sets one transmitter temporarily to STOP mode so that other commands can be entered.

**OPEN** [*aa*]<cr>

where

*aa* = Address of the transmitter (0 ... 99)

### CLOSE

The **CLOSE** command switches the transmitter back to the POLL mode.

#### Example:

```
>open 2      (opens the line to transmitter 2, other
transmitters stay in POLL mode)

>?          (for example, display device information)
...
>close      (line closed)
```

## Formatting Serial Line Message

**NOTE**

Instead of using the **FTIME** and **FDATE** commands described in this section, you can use the **FORM** command with modifiers **TIME** and **DATE**. See section **FORM** on page 100.

### FTIME and FDATE

**FTIME** and **FDATE** commands will enable/disable output of time and date to the serial line. To add time to **R** and **SEND** outputs enter:

**FTIME** [x]<cr>

To add date to **R** and **SEND** outputs enter:

**FDATE** [x]<cr>

where

x = ON or OFF

Example:

```
>send
aw= 0.277 T= 23.5 'C H2O= 16 ppm
>ftime on
Form. time : ON
>send
00:16:07 aw= 0.277 T= 23.5 'C H2O= 16 ppm
>fdate on
Form. date : ON
>send
2000-01-01 00:16:15 aw= 0.277 T= 23.5 'C H2O= 16 ppm
>
```

## General Settings

### Changing Quantities and Units

To change quantities and units use serial commands or the optional display/keypad. The MMT330 measures the following quantities:

- Water activity ( $a_w$ )
- Relative saturation (%RS)
- Temperature (T) (metric unit: °C, non-metric unit:°F)
- ppm for transformer oil only ( $H_2O$ )

**NOTE**

Only the quantities selected when ordering the device can be selected as display output quantities.

#### Using Display/Keypad

Use display/keypad to select the display output quantities.

1. Press any of the arrow buttons to open the **Main Menu**.
2. Press the ► arrow button to select **Display**.
3. Press ► arrow button to select **Quantities**.
4. Select the quantity by using the ▲ ▼ arrow buttons. Confirm the selection by pressing **SELECT**. You can select 1 ... 3 display quantities at a time.
5. Press **EXIT** to return to the basic display.

To select display units:

1. Press any of the arrow buttons to open the **Main Menu**.
2. Press the ► arrow button to select **Display**.
3. Use the ▲ ▼ arrow buttons to select **Units**. Confirm the selection by pressing the right-hand arrow button.
4. Use the ▲ ▼ arrow buttons to select display units. Confirm the selection by pressing **CHANGE**. The unit changes from metric to non-metric or the other way round.
5. Press **EXIT** to return to the basic display.

**NOTE**

Changing the display quantities/units (by using the display/keypad) has no effect on the serial output data.

## Using Serial Line

### FORM

Use the serial line command **FORM** to change the format or select a certain quantities for the output commands **SEND** and **R**.

**FORM** [x]<cr>

where

x = Formatter string

If no formatter string is entered, the command will display the currently active formatter string. Note that the hash symbol "#" is shown as a backslash "\" when viewing the current formatter string.

Formatter string consists of quantities and modifiers. The MMT330 measures the following quantities:

- Water activity ( $a_w$ )
- Relative saturation (%RS)
- Temperature (T) (metric unit: °C, non-metric unit:°F)
- ppm for transformer oil only (H<sub>2</sub>O) (optional quantity)

When selecting the quantity, use the abbreviations of the quantities.

The modifiers are presented in Table 25 on page 100 below.

**Table 25 FORM Command Modifiers**

Modifier	Description
x.y	Length modifier (number of digits and decimal places)
#t	Tabulator
#r	Carriage-return
#n	Line feed
""	String constant
#xxx	Special character, code "xxx" (decimal), for example #027 for ESC
U5	Unit field and length (length optional)
ADDR	Transmitter address [00...255]
SN	Transmitter serial number
TIME	Time [hh:mm:ss]
DATE	Date [yyyy-mm-dd]

Example:

```
>form "aw=" 6.4 aw #t "t=" 6.2 t #r#n
OK
>send
aw=      0.2644   t=      25.50
>
```

```

>form "Oil ppm= " h2o " " u3 #r#n
OK
>send
Oil ppm=      16.6 ppm
>
>>form "RS%=" " " U4 3.5 "T" T " " U3 6.0 "H2O=" H2O " " U5
\r \n
>OK
>send
RS%=      45.1%   T= 23.91169 'C H2O=      27 ppm
>

```

Command **FORM /** will return the default output format. The default output format depends on the device configuration.

```

>form /
OK
>send
aw=      0.087 T= 24.0 'C
>

```

## UNIT

Use the **UNIT** command to select metric or non-metric output units:

**UNIT** [x]<cr>

where

x = M or N

where

M = Metric units

N = Non-metric units

### NOTE

This command changes both the serial output and display units to either metric or non-metric units. When you want to output both metric and non-metric units simultaneously on the serial line and display, select the display units later by using the display/keypad.

## Date and Time

### Using Display/Keypad

If the optional Data Logger Module is installed, you can change the time and date using the display/keypad.

1. Press any of the arrow buttons to open the **Main Menu**.
2. Select **System** and press the ► arrow button to confirm your selection.
3. Select **Date and time** and press the ► arrow button.
4. Press the **SET** button to enter the adjustment mode, and use the arrow buttons to select and change the values.
5. You can also change the date and time formats that are shown in the graphs. The selected formats are only used in graphical display, they do not change the formats that are used in the serial communication.
6. Press **EXIT** to return to the basic display.

### Using Serial Line

To set time enter the **TIME** command. To set date enter the **DATE** command.

**TIME**<cr>

**DATE**<cr>

These time and date settings are shown on the timestamps of **PLAY** command. When you want to include time and date in the **R** and **SEND** commands, use the **FTIME** and **FDATE** commands.

Example:

```
>time
Time           : 13:42:49 ?

>date
Date           : 2007-05-31 ?
```

**NOTE**

If the optional Data Logger Module is not installed, time and date available on the serial ports (only) are cleared to 2000-01-01 00:00:00 at reset or at power failure.



## Data Filtering

The averaging data filter calculates an average over a certain period of time. The lowest measurement noise is achieved with the extended filtering. There are three filtering levels available.

**Table 26**      **Filtering Levels**

Setting	Filtering Level
OFF	No filtering (default setting).
STANDARD	Standard filtering. Approximately 13 s moving average.
EXTENDED	Extended filtering. Approximately 1 min average by default, but configurable on the serial line.

### Using Display/Keypad

1. Press any of the arrow buttons to open the **Main Menu**.
2. Select **Measuring** by pressing the ► arrow button.
3. Select **Filtering** and press **CHANGE** to confirm your selection.
4. Select **Off/Standard/Extended** and press **SELECT** to confirm your selection.
5. Press **EXIT** to return to the basic display.

### Using Serial Line

Use the serial line command **FILT** to set the filtering level.

**FILT** [*level*] [*extfactor*]<cr>

where

level      = Filtering level. The options are:

OFF (no filtering, default setting)

ON (standard filtering, approximately 13 s moving average)

EXT (extended filtering, approximately 1 min average by default but configurable by changing the extfactor)

extfactor = Weighted average factor for extended filtering level.  
Range 0 ... 1, default 0.030.

In extended filtering mode, the output is calculated based on the following formula:

$[(\text{new result} * \text{extfactor}) + (\text{old result} * (1.0 - \text{extfactor}))]$

This means that with extfactor value 1 the transmitter will take only the latest measurement into account, but with extfactor value 0.1 a new output is a combination of the previous output (90%) and the latest measurement (10%).

Example (enable standard filtering):

```
>filt on
Filter          : ON
>
```

## Device Information

Use the display/keypad or the serial line to display the device information.

Press the **INFO** button in the basic display to see the following information:

- Present or past unacknowledged errors, if any
- Device information
- Current date and time (only shown if data logger module installed)
- Adjustment information fed by the user
- Measuring settings
- Display Alarm settings
- Serial interface information
- Network settings and status of the LAN and WLAN interfaces
- Analog output information
- Relay output information (when applicable)



**Figure 57 Device Information on Display**

Proceed in the information views by pressing the **MORE** button repeatedly until you get the desired information. You can browse through the information displays also with arrow buttons. Press **OK** to return to the basic display.

**?**

Use the serial line command **?** to check the current transmitter configuration. Command **??** is similar but can also be used if the transmitter is in POLL mode.

**Example:**

```
>?
MMT330 / 2.04
Serial number : A3420002
Batch number  : A3210034
Adjust. date   : 2005-08-07
Adjust. info   : Pre-adjustment Vaisala/HEL
Date           : 2000-01-01
Time           : 02:32:27
Serial mode    : STOP
Baud P D S    : 4800 E 7 1
Output interval: 0 s
Address        : 0
Echo           : ON
Pressure       : 1013.25 hPa
Filter         : OFF
Ch1 output     : 4...20mA
Ch2 output     : 4...20mA
Ch3 output     : 4...20mA
Ch1 aw low    : 0.00
Ch1 aw high   : 1.00
Ch2 T low     : -40.00 'C
Ch2 T high    : 60.00 'C
Ch3 H2O low   : 0.00 ppm
Ch3 H2O high  : 500.00 ppm
Module 1      : not installed
Module 2      : AOUT-1
>
```

**LIGHT**

Use the **LIGHT** command to view or set the backlight mode of the display (optional). Issuing the command without specifying a mode shows the current backlight mode.

**LIGHT** [*mode*]<cr>

where

mode = Operating mode of the display backlight. The options are:

ON (backlight always on)

OFF (backlight always off)

AUTO (backlight automatically turns on and off when keypad is used)

**Example:**

```
>light
Backlight      : OFF
>light auto
Backlight      : AUTO
>
```

## HELP

Use the **HELP** command to list the commands. The available commands are determined by the device configuration and installed options.

Example:

```
>help
?          ACAL      ADDR      AERR      ALSEL
ASEL      CDATE    CLOSE    CON       CRH
CT        CTEXT    DATE     DELETE    DIR
DSEL      DSEND    ECHO     ERRS      FCRH
FILT      FORM     HELP     INTV      ITEST
LIGHT     LOCK     MODBUS   MODS      OIL
PLAY      R        RESET    SCOM      SDELAY
SEND      SERI     SMODE    SYSTEM    TEST
TIME      UNDELETE UNIT     VERS
>
```

## ERRS

Use the **ERRS** command to display transmitter error messages, see Table 30 on page 146.

Example (no active errors):

```
>errs
No errors
>
```

Example (showing active error):

```
>errs
Error: E2 Humidity sensor open circuit.
>
```

## MODS

Use the **MODS** command to display information about the optional modules that are connected to the transmitter.

Example:

```
>mods
Module 1      : WLAN-1 (POST: release_82000941_J; FW:
Version 82000977_K1 10/16/2008)
Module 2      : LOGGER-1      (1024 MB; HW: B; SW: 5)
>
```

## VERS

Use the **VERS** command to display software version information.

Example:

```
>vers
MMT330 / 5.10
>
```

## Resetting Transmitter by Using Serial Line

### RESET

Resets the device. The user port switches to start-up output mode selected with command **SMODE**.

## Locking Menu/Keypad Using Serial Line

### LOCK

Use the **LOCK** command to prevent the user from entering the menu using the keypad, or to lock the keypad completely. You can optionally set a 4-digit PIN code, for example 4444.

If a PIN code has been set, the user will be prompted to enter the code when trying to access the menu. Entering the code correctly will disable the lock until the user returns back to the basic view.

**LOCK** [x] [yyyy]<cr>

where

x = Keypad locking level, range 0...2. The options are:  
0 - No lock (enables full access)  
1 - Menu locked, but graphs are accessible  
2 - Keypad completely disabled

yyyy = 4-digit PIN code. The code can only be set when keypad locking level is 1.

Examples:

```
>lock 1 4444
Keyboard lock : 1 [4444]
>
```

```
>lock 1
Keyboard lock : 1
>
```

## Serial Output Settings

The communication settings for the user port can be changed via the serial line or by using the optional display/keypad. The communication settings for the service port are fixed and not changeable.

**NOTE**

If a communication module (LAN, WLAN, or RS-422/RS-485 interface) has been installed, the user port is not accessible. Any changes to the settings are applied to the interface provided by the module, if applicable.

### Using Display/Keypad

1. Press any of the arrow buttons to open the **Main Menu**.
2. Select **Interfaces** and press the ► arrow button to confirm your selection.
3. Select **Serial interface** and press the ► arrow button to confirm your selection.
4. Select **Bit rate** and **Serial format** by pressing the **CHANGE** button. Use the ▲ ▼ arrow buttons to select and press **SELECT** to confirm your selection.
5. Select the **Protocol** to be used by the serial output by pressing the **CHANGE** button. Select the option using the ▲ ▼ arrow buttons and press **SELECT**. This is the same serial mode setting that is changed by the **SMODE** serial command.
  - **RUN** mode continuously outputs the measurement message at the set interval. If you select the RUN mode, set the desired **RUN interval** also.
  - **POLL** mode enables multiple transmitters to share the same RS-485 line. If you select the POLL mode, select the **Device address** also, as each transmitter on the line must have a unique address.
  - In **STOP** mode, transmitter outputs the transmitter software version at reset or power-up and remains silent, waiting for commands.
  - The **SEND** mode is almost identical to the STOP mode. The only difference is that the transmitter outputs a measurement message at start-up, instead of software version.
  - In **MODBUS** mode, only Modbus protocol communication is available. See Chapter 5, Modbus, on page 131.
6. Select the **RUN interval** and the unit. Press **OK** to confirm.
7. Select the **Device address** and press **SET** to confirm.
8. Select **ECHO**, and press **ON** to turn it on, **OFF** to turn it off.
9. Press **EXIT** to return to the basic display.

The new user port settings set using the display/keypad are effective immediately.

## Using Serial Line

### NOTE

You can use the serial commands to change/view the user port settings even if you are currently connected to the service port.

### SERI

Use the **SERI** command to set the communication settings for the user port. Changed settings will be activated at next reset or power up.

**SERI** [*b p d s*]  
<cr>

where

- b** = Bit rate (110, 150, 300, 600, 1200, 2400, 4800, 9600, 19200, 38400, 57600, 115200)
- p** = Parity (n = none, e = even, o = odd)
- d** = Data bits (7 or 8)
- s** = Stop bits (1 or 2)

The settings can be changed one parameter at a time or all parameters at once.

Example (changing all parameters):

```
>seri 600 N 8 1
600 N 8 1
>
```

Example (changing parity only):

```
>seri o
4800 o 7 1
```

### SMODE

Use the **SMODE** command to set the user port start-up operating mode.

**SMODE** [*xxxx*]  
<cr>

where

- xxx** = STOP, SEND, RUN, POLL, or MODBUS.

**Table 27 Selection of Output Modes**

Mode	Measurement Output	Available Commands
STOP	Only with the <b>SEND</b> command.	All (default mode).
SEND	One measurement message automatically at start-up, then only with the <b>SEND</b> command.	All.
RUN	Automatic output.	Only command <b>S</b> .
POLL	Only with the <b>SEND [addr]</b> command.	<b>SEND [addr]</b> and <b>OPEN [addr]</b> . Other commands available after opening a line to the transmitter using the <b>OPEN</b> command.  Use with RS-485 buses where multiple transmitters can share the same line.
MODBUS	Must be read from the transmitter using Modbus protocol.	Modbus protocol only; see Chapter 5, Modbus, on page 131.

Selected output mode will be activated at next reset or power up.

## ADDR

Use the **ADDR** command to set the device address of the transmitter. Addresses are required for POLL mode and MODBUS mode (serial Modbus).

**ADDR [aa]<cr>**

where

*aa* = Device address of the transmitter, range 0 ... 255 (default = 0)

Example (changing the transmitter address from 0 to 52):

```
>addr
Address      : 0 ? 52
>
```

## INTV

Use the **INTV** command to set the RUN mode output interval. The time interval is used only when the RUN mode is active. Setting the interval to zero enables the fastest possible output rate.

**INTV [xxx yyy]<cr>**

where

*xxx* = Delay, range 0 ... 255.

*yyy* = Unit: S, MIN or H.



Example (setting the output interval to 10 minutes):

```
>intv 10 min
Output interval: 10 min
>
```

## SDELAY

With the **SDELAY** command you can set delay (response time) for user port, or view currently set delay value. Adjusting the delay may be needed when half-duplex communication (typically two-wire RS-485) is used.

The delay value corresponds to tens of milliseconds (for example, 5 = 0.050s minimum answer delay). The value can be set between 0 ... 254.

Example:

```
>sdelay
Serial delay   : 0 ? 10

>sdelay
Serial delay   : 10 ?
```

## ECHO

Use the **ECHO** command to set the user port echo. The command either enables or disables echo of characters received.

**ECHO** [x]<cr>

where

x = ON (enabled, default) or OFF (disabled)

### NOTE

When using the RS-485 interface with a 2-wire connection, always disable echo. When using a RS-232, RS-422/485 4-wire connection, LAN, or WLAN, you can enable or disable it as you wish.

## Data Recording

Data recording function is always on and collects data automatically into the memory of the device. If the optional data logger module is installed, the transmitter uses it automatically. Recorded data does not disappear from the memory when the power is switched off. Collected data can be observed in a form of a graph in the graphical view of the display or it can be listed out by using the serial line or MI70 Link program.

## Selecting Data Recording Quantities

If the device is provided with the optional display, the recorded quantities are always those selected for the display. Up to three quantities can be recorded at a time. See section Changing Quantities and Units on page 99 for instructions on how to select the display quantities with the keypad.

### DSEL

Use the serial line command **DSEL** to select the quantities to be recorded if the transmitter is not equipped with display/keypad. The MMT330 measures the following quantities:

- Water activity (aw)
- Relative saturation (%RS)
- Temperature (T) (metric unit: °C, non-metric unit:°F)
- ppm for transformer oil only (H<sub>2</sub>O) (optional quantity)

**DSEL** [xxx]<cr>

where

xxx = Data recording quantity.

Example:

```
>dsel aw t
aw T
>
```

Enter the command without parameters and press **ENTER** to display the current recording parameters.

## View Recorded Data

If the device is provided with the optional display, the graphical display shows the data of the selected quantities, one at a time. See section Graphic History on page 68 for details about graphical display.

You may also dump the logged data to the serial line in numeric form with the following commands.

## DIR

Use the serial line and enter the **DIR** command to check the available files.

Without the data logger module, the device records six files (six observation periods) for each selected quantity. The data logger raises the number of recorded files to seven for each quantity. Thus, the total amount of the files varies between 6 and 21. See Table 11 on page 68.

Select, for example, three quantities (aw, T and H<sub>2</sub>O). The last column illustrates the number of data points that has been stored in the file.

Example (data logger module installed):

```
>dir
  File description           Oldest data available           No. of points
1  aw  (10 s intervals)     2007-05-30 08:26:50           13996800
2  aw  (90 s intervals)     2007-05-30 05:25:30           1555200
3  aw  (12 min intervals)   2007-05-29 05:48:00           194400
4  aw  (2 h intervals)      2007-05-19 02:00:00           19440
5  aw  (12 h intervals)     2007-03-23 12:00:00           3240
6  aw  (3 d intervals)      2006-04-20 00:00:00           540
7  aw  (12 d intervals)     2002-12-16 00:00:00           135
8  T   (10 s intervals)     2007-05-30 08:26:50           13996800
9  T   (90 s intervals)     2007-05-30 05:25:30           1555200
10 T   (12 min intervals)   2007-05-29 05:48:00           194400
11 T   (2 h intervals)      2007-05-19 02:00:00           19440
12 T   (12 h intervals)     2007-03-23 12:00:00           3240
13 T   (3 d intervals)      2006-04-20 00:00:00           540
14 T   (12 d intervals)     2002-12-16 00:00:00           135
15 H2O (10 s intervals)     2007-05-30 08:26:50           13996800
16 H2O (90 s intervals)     2007-05-30 05:25:30           1555200
17 H2O (12 min intervals)   2007-05-29 05:48:00           194400
18 H2O (2 h intervals)      2007-05-19 02:00:00           19440
19 H2O (12 h intervals)     2007-03-23 12:00:00           3240
20 H2O (3 d intervals)      2006-04-20 00:00:00           540
21 H2O (12 d intervals)     2002-12-16 00:00:00           135
>
```

## Example (without data logger module):

```
>dir
  File description           Oldest data available       No. of points
1  RS   (10 s intervals)    2008-04-11 23:41:10        135
2  RS   (90 s intervals)   2008-04-11 20:41:11        135
3  RS   (12 min intervals) 2008-04-10 21:03:41        135
4  RS   (2 h intervals)    2008-03-31 18:03:41        135
5  RS   (12 h intervals)   2008-02-04 12:03:41        135
6  RS   (3 d intervals)    2007-03-04 00:03:41        135
7  T    (10 s intervals)    2008-04-11 23:41:11        135
8  T    (90 s intervals)   2008-04-11 20:41:11        135
9  T    (12 min intervals) 2008-04-10 21:03:41        135
10 T    (2 h intervals)    2008-03-31 18:03:41        135
11 T    (12 h intervals)   2008-02-04 12:03:41        135
12 T    (3 d intervals)    2007-03-04 00:03:41        135
13 H2O  (10 s intervals)    2008-04-11 23:41:11        135
14 H2O  (90 s intervals)   2008-04-11 20:41:11        135
15 H2O  (12 min intervals) 2008-04-10 21:03:41        135
16 H2O  (2 h intervals)    2008-03-31 18:03:41        135
17 H2O  (12 h intervals)   2008-02-04 12:03:41        135
18 H2O  (3 d intervals)    2007-03-04 00:03:41        135
>
```

## PLAY

Use the **PLAY** command to output the selected file to the serial line. If the data logger module is installed, you can specify an interval to be outputted.

Data in the output is <TAB> delimited. This is compatible with most spreadsheet programs. Before giving the command, set the local date and time with **TIME** and **DATE** commands, if needed.

**PLAY** [x] [*start\_date start\_time end\_date end\_time*]<cr>

where

- x = Number of the data file that will be outputted, range 0...21. The numbers correspond to the output of the DIR command; refer to the example on page 113. Selecting number 0 will output all data files.
- start\_date = Starting date of the interval to be outputted. Must be given in the following format: yyyy-mm-dd.
- start\_time = Starting time of the interval to be outputted. Must be given in the format hh:mm:ss or h:mm.
- end\_date = Ending date of the interval to be outputted. Must be given in the following format: yyyy-mm-dd.
- end\_time = Ending time of the interval to be outputted. Must be given in the format hh:mm:ss or h:mm.

Example:

```
>play 3 2007-05-05 00:00:00 2007-05-06 00:00:00
aw (12 min intervals) 2007-05-05 00:00:00 121
Date           Time           trend           min           max
yyyy-mm-dd    hh:mm:ss
2007-05-05    00:00:00  0.2701         0.2700        0.2705
2007-05-05    00:12:00  0.2711         0.2702        0.2718
2007-05-05    00:24:00  0.2708         0.2708        0.2710
2007-05-05    00:36:00  0.2710         0.2702        0.2720
...
```

You can use the <ESC> key to interrupt the output listing.

**NOTE**

Output of large amounts of recorded data can result in huge data files and take a long time, up to several days for the entire memory of the data logger at 10 second resolution. To make it easier to process the data it is recommended to select the largest suitable data interval, and to specify the start and end times carefully.

## Deleting the Recorded Files

You can delete the recorded data files using the keypad/display, or the **DELETE** command on the serial line. The deletion is always done for all data; you cannot delete individual files.

Note that the transmitter automatically overwrites the old data when the memory is full, so manual deletion of the recorded files is not necessary in normal use.

To delete the data files using the keypad/display:

1. Press any of the arrow buttons to open the **Main Menu**.
2. Select **System** by pressing the ► arrow button.
3. Select **Clear graph memories** by pressing the **CLEAR** button. Press the **YES** button to confirm the selection.

**CAUTION**

This function clears the entire data history of the transmitter, including all graphs and the content of the optional data logger module.

## UNDELETE

Similarly to the **DELETE** command, the **UNDELETE** command is used without any arguments. It will recover all deleted data that has not been overwritten yet.

## Analog Output Settings

The analog outputs are set in the factory according to the order form. In case you want to change the settings, follow these instructions. See section Third Analog Output on page 53.

### Changing Output Mode and Range

Both output channels have their own DIP switch module with 8 switches, see the position in Figure 2 on page 21 (DIP switches for analog output settings).

1. Select the current/voltage output, switch ON either of the switches, 1 or 2.
2. Select the range, switch ON one of the switches from 3 to 7.

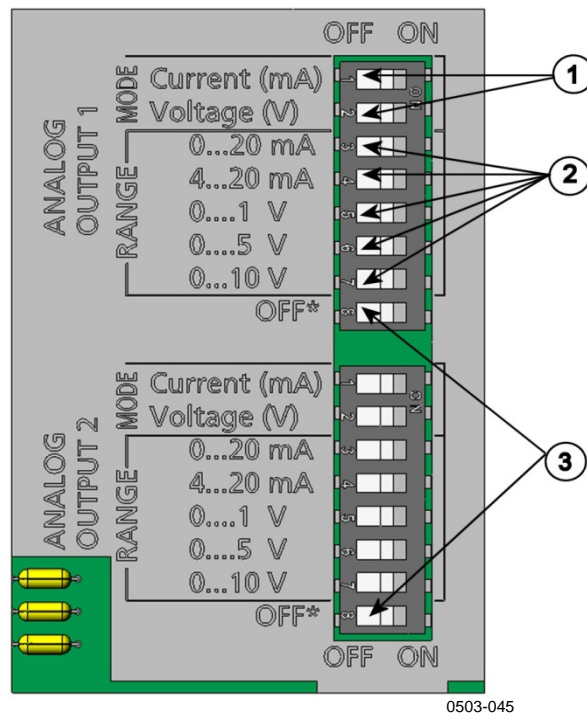

**Figure 58** Current/Voltage Switches of Output Modules

The following numbers refer to Figure 58 above:

- 1 = Current/voltage selection output switches (from 1 to 2)
- 2 = Current/voltage range selection switches (from 3 to 7) in analog output 1 and 2
- 3 = Switches for service use only. Keep in OFF position always.

#### NOTE

Only set one mode and one range switch to ON for one output channel. The rest of the switches must remain OFF.

Example: 0 ... 5 V voltage output selected for channel 1 and 4...20 mA selected for channel 2.

	OFF	ON	Selection	
1	■		Voltage output selected	
2		■		
3	■		0 ... 5 V selected	
4	■			
5	■			
6		■		
7	■		Current output selected	
8	■			
1		■		Current output selected
2	■			
3	■			4 ... 20 mA selected
4		■		
5	■			
6	■			
7	■			
8	■			

## NOTE

If you have customized the error output setting (**AERR**), check that the set error values are still valid after changing the output mode/range. See section Analog Output Fault Indication Setting on page 120.

## Analog Output Quantities

Use the display/keypad to change and scale the analog output quantities.

1. Press any of the arrow buttons to open the **Main Menu**.
2. Select **Interfaces** by pressing the ► arrow button.
3. Select **Analog outputs** by pressing the ► arrow button.
4. Select **Output 1/2/3** by pressing the ► arrow button.
5. Select **Quantity** by pressing the ▲▼ arrow buttons. Confirm your selection by pressing **CHANGE**.
6. Select the quantity by using the arrow buttons. Press **SELECT** to confirm your selection.
7. Select **Scale**, lower limit, by pressing the ▲▼ arrow buttons. Press **SET** to confirm your selection. Press **OK** to confirm your setting.
8. Select the upper limit by pressing the ▲▼ arrow buttons. Use the arrow buttons to set the upper limit value. Press **SET** to confirm your selection. Press **OK** to confirm your setting.
9. Press **EXIT** to return to the basic display.

## AMODE/ASEL

Use the serial line to select and scale the analog output quantities. Check the analog output modes with the **AMODE** command.

**AMODE**<cr>

Example:

```
>amode
Ch1 output      : 0...1V
Ch2 output      : 0...1V
>
```

Select and scale the quantities for the analog outputs with the command **ASEL**. Note that the optional quantities can be selected only if they have been selected when ordering the device.

**ASEL** [xxx yyy zzz]<cr>

where

xxx = Quantity of channel 1  
yyy = Quantity of channel 2  
zzz = Quantity of the optional analog output channel 3

Always enter the quantities for all outputs. The MMT330 measures the following quantities:

- Water activity ( $a_w$ )
- Relative saturation (%RS)
- Temperature (T) (metric unit: °C, non-metric unit:°F)
- ppm for transformer oil only (H<sub>2</sub>O) (optional quantity)

Use the **ASEL** [xxx yyy] command as shown in the example below when using a device with two analog outputs.

Example:

```
>asel aw t
Ch1 aw   low  : 0.00
Ch1 aw   high : 1.00
Ch2 T    low  : -40.00 'C
Ch2 T    high : 60.00 'C
>
```



## Analog Output Tests

Use the display/keypad to test the operation of the analog outputs by forcing the outputs to known values. Measure then the outputs with a current/voltage meter.

1. Press any of the arrow buttons to open the **Main Menu**.
2. Select **System** by pressing the ► arrow button.
3. Select **Diagnostics** by pressing the ► arrow button.
4. Select **Analog output tests** by pressing the ► arrow button.
5. Select one of the testing options **Force 0%/50%/100% of scale**. Press **TEST** to confirm your selection. All outputs are tested simultaneously. The actual output value depends on the selected range.
6. Press **OK** to stop testing. Press **EXIT** to return to the basic display.

### ITEST

Use the **ITEST** command to test the operation of the analog outputs. The **ITEST** command forces the analog outputs to entered values. The analog outputs remain at these values until you enter the command **ITEST** without parameters or reset the transmitter.

**ITEST** [*aa.aaa bb.bbb cc.ccc*]  
<cr>

where

*aa.aaa* = Current or voltage value to be set for channel 1 (mA or V)  
*bb.bbb* = Current or voltage value to be set for channel 2 (mA or V)  
*cc.ccc* = Current or voltage value to be set for channel 3 (optional)  
 (mA or V)

Example:

```
>itest 20 5
Ch1 (aw ) : * 20.000 mA H'CCDA
Ch2 (T ) : * 5.000 mA H'34B9
>
```

## Analog Output Fault Indication Setting

Factory default state for analog outputs during error condition is 0 V/ 0 mA. Please be careful when selecting the new error value. The error state of the transmitter should not cause unexpected problems in process monitoring.

Use the display/keypad to set the analog output fault indication.

1. Press any of the arrow buttons to open the **Main Menu**.
2. Select **Interfaces** by pressing the ► arrow button.
3. Select **Analog Outputs** by pressing the ► arrow button.
4. Select **Output 1/2/3** by pressing the ► arrow button.
5. Select **Fault indication**. Press **SET** to confirm your selection. Enter the fault indication value by using the arrow buttons. Press **OK** to confirm your setting. This value is outputted if a transmitter error occurs.
6. Press **EXIT** to return to the basic display.

### AERR

Use the serial line **AERR** command to change the error output.

**AERR**<cr>

Example:

```
>aerr
Ch1 error out : 0.000V ? 5.0
Ch2 error out : 0.000V ? 5.0
>
```

**NOTE**

The error output value must be within a valid range of the output mode.

**NOTE**

The error output value is displayed only when there are minor electrical faults such as a humidity sensor damage. When there is a severe device malfunction, the error output value is not necessarily outputted.

## Extend Analog Output Range

Use the **AOVER** command to allow the analog output channels to exceed their specified range by 10%. The scaling of the parameter remains as before; the extra range is used for additional measurement range in the high end of the scale.

**AOVER** [*ON/OFF*]  
<cr>

Example:

```
>aover on  
Extended output: ON  
>
```

The following example illustrates how the analog output is affected. Channel 2 outputs temperature (T) with voltage output 0 ... 5 V (0 ... 60 °C). After giving the **AOVER ON** command, the range is 0 ... 5.5 V (0 ... 66 °C). Note that the 60 °C point is still at 5 V.

## Operation of Relays

### Quantity for Relay Output

A relay monitors the quantity chosen for the relay output. Any of the quantities available can be chosen.

### Relay Setpoints

When the measured value is in between the "above" and "below" values, the relay is passive. When choosing lower value as "above" value and higher value as "below" value, the relay is passive when the measured value is not between the setpoints. You can also set only one setpoint. See Figure 59 on page 122 for illustrative examples of the different measurement-based relay output modes.

**Mode 1: Only "above" setpoint set**

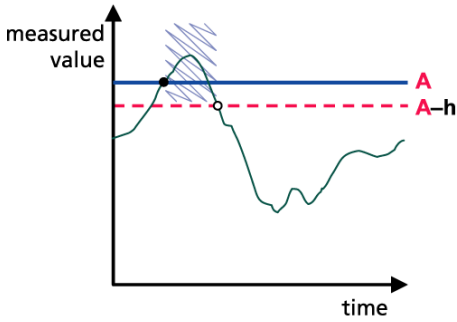

Relay is active when value is above the setpoint.

**Mode 2: Only "below" setpoint set**

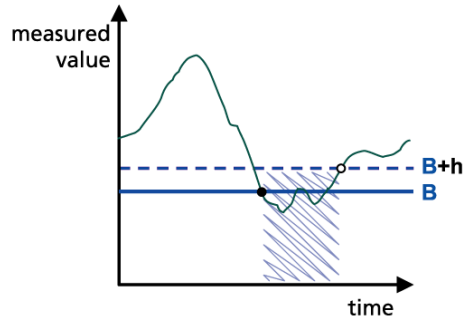

Relay is active when value is below the setpoint.

**Mode 3: Both setpoints set, "above" > "below"**

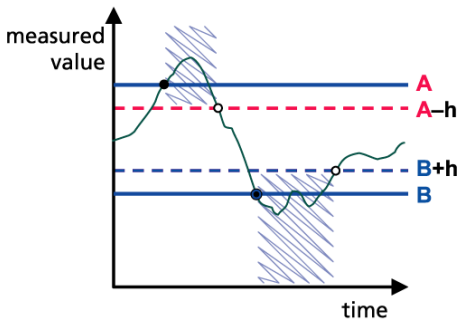

Relay is active when value is outside the setpoints.

**Mode 4: Both setpoints set, "above" < "below"**

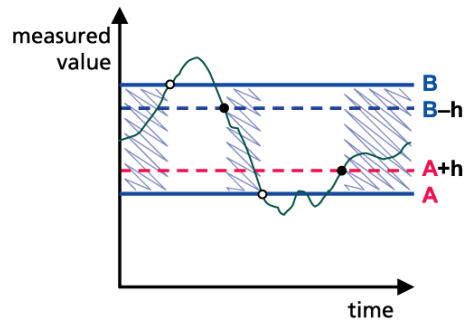

Relay is released when value is outside the setpoints.

**Legend**

- |  |  |
|--|--|
| <b>A</b> "Active above" setpoint value | Relay is active ( <b>NO</b> – C connected) |
| <b>B</b> "Active below" setpoint value | • Relay is activated                       |
| <b>h</b> Hysteresis value              | ○ Relay is released                        |

1102-007

**Figure 59 Measurement-Based Relay Output Modes**

## Hysteresis

Hysteresis function is to prevent the relay switching back and forth when the measured value is near to the setpoint values.

Relay is activated when the measured value passes the exact value of the setpoint. When returning and passing the setpoint again relay is not released before the value reaches the setpoint increased/decreased by the hysteresis value.

Hysteresis should be smaller than difference of the setpoints.

Example: When the 'active above' value  $a_w$  is 0.6 and the hysteresis value is 0.05, relay activates when  $a_w$  reaches 0.60. As the humidity decreases, relay releases at 0.55.

### NOTE

If both setpoints are specified and "above" setpoint is lower than "below" setpoint, the hysteresis works in the opposite direction, that is, relay is **released** when the measured value passes the exact value of the setpoint.

## Relay Indicating Transmitter Error Status

You can set a relay to follow the operation status of the device. By selecting FAULT/ONLINE STATUS for output quantity a relay changes state on the basis of the operation status as follows:

### FAULT STATUS

Normal operation: relay active (C and NO outputs are closed)

Not measuring state (error state or power off): relay released (C and NC outputs are closed)

### ONLINE STATUS

Live measurement (data available): relay active (C and NO outputs are closed)

No live data (for example: error state, chemical purge or adjustment mode): relay released (C and NC outputs are closed)

See Figure 60 on page 124 for illustrative examples of the FAULT/ONLINE STATUS relay output modes.

### Analog output vs. "FAULT STATUS" relay

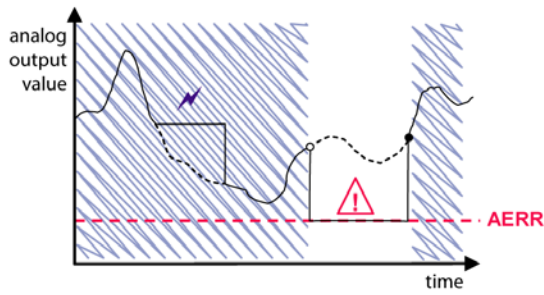

Relay is released in case of a measurement failure only.

### Analog output vs. "ONLINE STATUS" relay

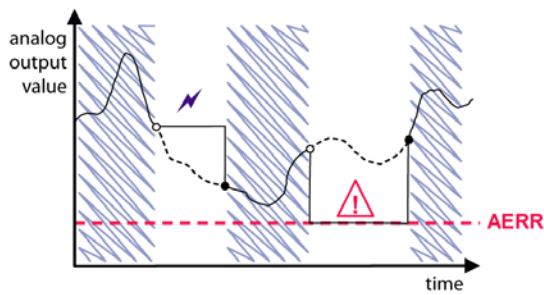

Relay is released when the output values are frozen, the adjustment mode is activated, or an instrument failure is detected

**Legend**

- AERR** Analog output "fault indication" value set by user
- ⚡ Outputs frozen because of e.g. Purge
- ⚠ Measurement failure because of e.g. damaged sensor
- True value of the measurement parameter during the exceptional situation
- ▨ Relay active (NO – C connected)
- Relay is activated
- Relay is released

1102-040

**Figure 60 FAULT/ONLINE STATUS Relay Output Modes**

FAULT/ONLINE STATUS relays are usually used in conjunction with an analog output to obtain validity information for the output value.

**NOTE** If transmitter loses its power, all status-based relays are released similarly to the case of an instrument failure.

**Table 28 Relay State Examples**

Criterion for Relay Activation	Transmitter Operation Status	NC-C Connected	NO-C Connected
Not chosen			
	Power off		
$a_w$ below 0.5*	Measured $a_w$ above 0.5		
	Measured $a_w$ below 0.5		
$a_w$ above 0.5*	Measured $a_w$ above 0.5		
	Measured $a_w$ below 0.5		
Fault status	Measurement OK		
	Error active		
Online status	Measurement live		
	Error active		

\* Hysteresis has an effect when relay switching is based on live measurement. See section Hysteresis on page 123.

## Enabling/Disabling Relays

You can deactivate the relay outputs for example for service purposes of your system.

## Setting Relay Outputs

### NOTE

When you have only one relay module installed, its relays are called “relay 1” and “relay 2”.

When you have two relay modules, the relays of the module connected to slot **MODULE 1** are called “relay 1” and “relay 2” and relays connected to slot **MODULE 2** are called “relay 3” and “relay 4”.

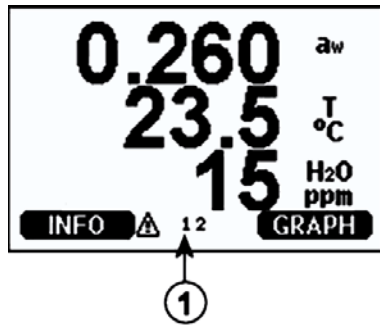

0509-142

**Figure 61 Relay Indicators on Display**

The following number refers to Figure 61 above:

- 1 = Lists enabled relays. Activation state shown in black. Disabled relays are not shown.

Use the display/keypad to set the relay outputs.

1. Press any of the arrow buttons to open the **Main Menu**.
2. Select **Interfaces**, confirm by pressing the ► arrow button.
3. Select **Relay outputs**, confirm by pressing the ► arrow button.
4. Select **Relay 1/2/3/4**, confirm by pressing the ► arrow button.
5. Select the **Quantity**, confirm by pressing **Change**. Select the Quantity by using the arrow buttons. Confirm your selection by pressing **Select**.
6. Select **Act. above / Act. below**. Press **SET** to confirm your selection. (If asked, select **MODIFY** if you want to set the setpoint by using the arrow buttons. Select **REMOVE** if you want to remove the setpoint.)
7. Select **Hysteresis** by using the arrow buttons. Press **SET** to set the hysteresis. Press **OK**.
8. Select **Relay enable** by using the arrow buttons, press **ON/OFF** to enable/disable the relay.



## RSEL

Use the serial line to select the quantity, setpoints and hysteresis or enable/disable the relay outputs. Enter the **RSEL** command.

**RSEL** [*q1 q2 q3 q4*]<cr>

where

*q1* = Quantity for the relay 1 or Fault/Online  
*q2* = Quantity for the relay 2 or Fault/Online  
*q3* = Quantity for the relay 3 or Fault/Online  
*q4* = Quantity for the relay 4 or Fault/Online

Factory setting: All relays disabled.

The MMT330 measures the following quantities:

- Water activity (aw)
- Relative saturation (%RS)
- Temperature (T) (metric unit: °C, non-metric unit:°F)
- ppm for transformer oil only (H<sub>2</sub>O) (optional quantity)

Example of window limit switch: Selecting relay 1 to follow a<sub>w</sub> measurement and relay 2 to follow temperature measurement. Two relay setpoints are set for both relays.

```
>rsel aw t
Rel1 aw  above: 0.00 ? 0.3
Rel1 aw  below: 0.00 ? 0.4
Rel1 aw  hyst : 0.00 ? 0.02
Rel1 aw  enabl: OFF ? on
Rel2 T   above: 0.00 'C ? 30
Rel2 T   below: 0.00 'C ? 40
Rel2 T   hyst : 0.00 'C ? 3
Rel2 T   enabl: OFF ? on
```

Example of normal limit switch: Selecting relay 1 to follow  $a_w$ , relay 2 to follow temperature, relay 3 to follow online status, and relay 4 to follow fault status.

```
>rsel aw t online fault
Rel1 aw   above: 0.00 ? 0.8
Rel1 aw   below: 0.00 ? 1.0
Rel1 aw   hyst  : 0.00 ? 0.01
Rel1 aw   enabl: ON ?
Rel2 T    above: 0.00 'C ? 30
Rel2 T    below: 0.00 'C ? 60
Rel2 T    hyst  : 0.00 'C ? 2
Rel2 T    enabl: ON ?
Rel3 ONLI above: -
Rel3 ONLI below: -
Rel3 ONLI hyst  : -
Rel3 ONLI enabl: ON ?
Rel4 FAUL above: -
Rel4 FAUL below: -
Rel4 FAUL hyst  : -
Rel4 FAUL enabl: ON ?
```

Example of using relay 1 as fault alarm: Selecting relay 1 to follow the fault status and relay 2 to follow the temperature measurement.

```
>rsel fault t
Rel1 FAUL above: -
Rel1 FAUL below: -
Rel1 FAUL hyst  : -
Rel1 FAUL enabl: ON ?
Rel2 T    above: 0.00 'C ? 30
Rel2 T    below: 0.00 'C ? -
Rel2 T    hyst  : 0.00 'C ? 2
Rel2 T    enabl: OFF ? ON
>
```

## Testing Operation of Relays

Testing activates relays even if they are disabled.

Use the module push buttons to activate the relays. Press the **REL 1** or **REL 2** button to activate the corresponding relay.

Relay is activated:	LED is lit
Relay is not activated:	LED is not lit

### RTEST

Use the serial line command **RTEST** to test the operation of the relays.

**RTEST** [*x1 x2 x3 x4*]  
<cr>

where

*x* = ON/OFF

Example: Activate and then release all four relays.

```
>rtest on on on on
  ON ON ON ON
>
>rtest off off off off
  OFF OFF OFF OFF
>
```

Enter the command **RTEST** without parameters to stop testing.

This page intentionally left blank.

## CHAPTER 5

# MODBUS

This chapter contains information that is needed when operating the transmitter using the Modbus protocol.

## Overview of Modbus Protocol Support

The MMT330 transmitter can be accessed using the Modbus serial communication protocol. Support for Modbus protocol is available on all MMT330 transmitters as a standard feature from software version 5.10 onward. The supported Modbus variants and the connections they use are listed in Table 29 below.

**Table 29 Supported Modbus Variants**

Supported Modbus Variant	Connections
Modbus RTU (Serial Modbus)	RS-232 (standard User Port) RS-422/485 interface (optional module)
Modbus TCP (Ethernet Modbus)	LAN interface (optional module) WLAN interface (optional module)

The supported Modbus functions, registers, configuration options, and diagnostics are described in Appendix A, Modbus Reference, on page 171.

Note the following limitations of the Modbus implementation:

- Modbus TCP mode accepts only one TCP connection at a time. Design the system so that only one Modbus TCP client accesses the transmitter.
- Modbus TCP can process reliably only one Modbus transaction at a time. Reduce the polling rate of the client to avoid nested transactions.

## Taking Modbus into Use

To take the Modbus protocol into use on the MMT330, you must perform some configuration tasks using the built-in display and keypad (optional) or a PC connected to the serial line. For example, you can connect to the service port using the USB service cable (Vaisala order code: 219685). The transmitter must be powered from a suitable power supply during configuration.

Instructions for performing the configuration are provided in the following sections:

- Enabling Serial Modbus on page 133
- Enabling Ethernet Modbus on page 134

After configuring the transmitter, perform the transmitter installation and wiring according to the instructions in Chapter 3, Installation, on page 27.

The configuration instructions assume you are familiar with the use of the transmitter. Additional details on the display/keypad, service port use, and serial commands are available in other sections of this manual:

- The use of the display/keypad option is described in section Display/Keypad (Optional) on page 67.
- If this is the first time you are using the USB service cable, you can find detailed instructions in section Installing the Driver for the USB Cable on page 81. You must install the required driver before using the service cable.
- Configuration of the LAN and WLAN interfaces is described in section LAN Communication on page 82.
- The serial commands available through the service port are described beginning from section List of Serial Commands on page 93.

## Enabling Serial Modbus

In addition to enabling the Modbus protocol in the device, Modbus over RS-232 or RS-485 needs the following software settings: serial bit rate, parity, number of stop bits, and Modbus device address.

### Using Display/Keypad (Optional)

1. Open the **Main Menu** by pressing any of the ▼ ▲ ◀ ▶ arrow buttons.
2. Navigate to **Interfaces ▶ Serial Interface**.
3. On the **Serial Interface** settings screen:
  - Enable the Modbus protocol.
  - Change the baud rate and parity if necessary.
  - Set the Modbus device address.

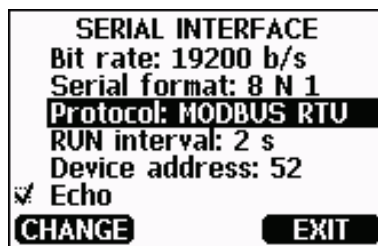

1101-033

Figure 62 Serial Interface Settings

4. After changing the settings, press the **EXIT** button. The Modbus configuration is now complete, as configuration changes made with the display and keypad are effective immediately.

### Using Serial Line

1. Open the transmitter cover.
2. Connect power supply wiring (if not using the power supply module) and power up the transmitter.
3. Connect the USB service cable between a computer and the service port of the transmitter.
4. Start the Vaisala USB Instrument Finder program (which has been installed on the computer along with the USB service cable driver), and check the COM port that the cable is using.
5. Open a terminal program, and connect to the service port. The fixed serial line settings of the service port are 19200, 8, 1, N.

6. Use the **SMODE** command to enable the Modbus mode:

```
>smode modbus  
Serial mode      : MODBUS  
>
```

7. If necessary, use the **SERI** command to check and/or change the serial interface settings for the User Port. For example, to set the User Port serial settings to 19200 N 8 1, issue the following command:

```
>seri 19200 N 8 1
```

**NOTE**

The number of data bits must always be 8 for Modbus RTU.

Serial Modbus interface of the MMT330 does not work with baud rates 115, 150, and 300 b/s.

8. Use the **ADDR** command to set the Modbus address of the transmitter. For example, to set the Modbus address to 52, issue the following command:

```
>addr 52
```

You must set a non-zero address or Modbus RTU will not work.

9. Modbus configuration is now complete. Reset or power cycle the transmitter to enable the Modbus mode, and proceed with the installation of the transmitter and the wiring of the serial interface.

## Enabling Ethernet Modbus

In addition to enabling the Modbus protocol in the device, Modbus TCP needs the following software settings: IP address, subnet mask, and default gateway address. Also network name (SSID) and security settings must be configured if wireless network is used.

### Using Display/Keypad (Optional)

1. Open the **Main Menu** by pressing any of the ▼ ▲ ◀ ▶ arrow buttons.
2. Navigate to **Interfaces ► Network Settings ► IP Configuration**.
3. On the **IP Configuration** screen, set the network configuration settings, and exit to save the changes.



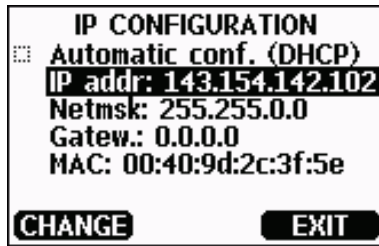

1101-034

**Figure 63 IP Configuration**

4. Navigate back to the **Network Settings** menu. If you are using the WLAN interface, select **Wireless LAN Settings**.
5. On the **Wireless LAN Settings** screen, set the network name (SSID) and security options, and exit to save the changes.



1101-036

**Figure 64 Wireless LAN Settings**

6. Navigate back to the **Network Settings** menu. Select **Communication Protocol**.
7. On the **Communication Protocol** screen, enable the Modbus protocol. Press the **EXIT** button to save the changes.

Note that the device address setting is not relevant for Modbus TCP. In the Modbus mode, the transmitter will respond to all valid Modbus messages with any “unit identifier” value.

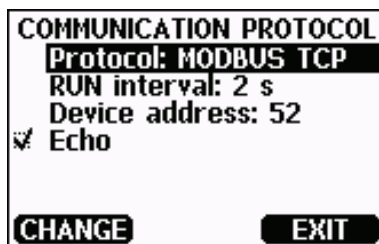

1101-034

**Figure 65 Communication Protocol**

8. Modbus configuration is now complete, as configuration changes made with the display and keypad are effective immediately.

## Using Serial Line

1. Open the transmitter cover.
2. Connect power supply wiring (if not using the power supply module) and power up the transmitter.
3. Connect the USB service cable between a computer and the service port of the transmitter.
4. Start the Vaisala USB Instrument Finder program (which has been installed on the computer along with the USB service cable driver), and check the COM port that the cable is using.
5. Open a terminal program, and connect to the service port. The fixed serial line settings of the service port are 19200, 8, 1, N.
6. Use the **SMODE** command to enable the Modbus mode:

```
>smode modbus
serial mode      : MODBUS
>
```

7. Configure the networking parameters of the interface you are using:

### NOTE

After transmitter startup, it may take a few minutes for the network interface to become available for configuration.

- a. Use the **NET** command to configure the networking parameters of both LAN and WLAN interface. You can, for example, enter the command without parameters and enter the settings as prompted:

```
>net
DHCP                : ON ? OFF
IP address          : 0.0.0.0 ? 143.154.142.102
Subnet mask         : 0.0.0.0 ? 255.255.0.0
Default gateway: 0.0.0.0 ?
Web config.        : ON ? OFF
Save changes (Y/N) ? y
OK
>
```

- b. If you are using the WLAN interface, use the **WLAN** command to configure the network name (SSID) and security settings. For example:

```
>wlan
Network SSID       : NAME ? NETWORKID
Type               : OPEN ? WPA-PSK/TKIP
WPA-PSK phrase ? thequickbrownfox
Save changes (Y/N) ? y
OK
>
```

For a description of the available settings, see section Wireless LAN Configuration on page 86.

8. Modbus configuration is now complete. Reset or power cycle the transmitter to enable the Modbus mode, and proceed with the installation of the transmitter.

## Diagnostic Modbus Counters

MMT330 has diagnostic counters that can be used to pinpoint Modbus problems. The counters are always active when the Modbus protocol is enabled.

### Viewing Counters Using Display/Keypad

You can use the display/keypad option to view and clear the counters. Enter the **Main Menu** and navigate to **System ► Diagnostics ► MODBUS Counters**.

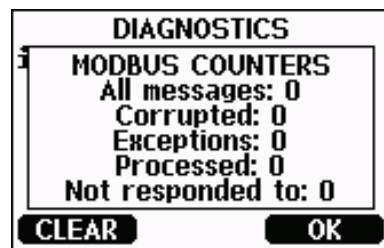

1101-037

Figure 66 Modbus Counters

### Viewing Counters Using Service Port

Use the **MODBUS** command to view the counters:

**MODBUS**<cr>

Example:

```
>modbus
Bus messages      : 0
Bus comm. error  : 0
Bus exceptions   : 0
Slave messages   : 0
Slave no resp.   : 0
Last message     :
>
```

In addition to the diagnostic counters, the last message (received or transmitted) is shown in hexadecimal format. If the last message was a broadcast message, the suppressed response message is shown.

The last message displayed may be incomplete if there is active Modbus traffic while using the **MODBUS** command.

Modbus RTU only: If the last received message was rejected because of bad CRC checksum, the **MODBUS** command displays the message with corrected CRC (last two bytes updated).

To clear the counters, select again the Modbus mode with the **S.MODE** command:

```
>smode modbus
```

## Disabling Modbus

If you stop using Modbus with the transmitter, set the transmitter to some other operating mode using the display/keypad option or the **S.MODE** command.

For example, to return the transmitter to the RUN mode where the measurements are output at regular intervals, issue the following command through the service port:

```
>smode run
```

Alternatively, you can enter the **Main Menu** using the display/keypad option, and change the mode from the **Interfaces** submenu.

The other communication settings of the output interface (User Port, LAN interface, or WLAN interface) will remain as configured, but the Modbus protocol will be disabled.

## CHAPTER 6

# PPM CONVERSION

This chapter contains information on conversion models.

## MMT330 ppm Conversion for Transformer Oils

Traditionally, moisture in transformer oil is measured by using ppm units. The ppm output shows the average *mass concentration of water* in oil. MMT330 has an option for ppm output provided that this has been selected when ordering the transmitter. Vaisala has this conversion readily available for mineral transformer oils.

## Conversion Model with Average Coefficients

The conversion model of the MMT330 is based on the average water solubility behaviour of transformer oils. The ppm output is calculated as follows:

$$ppm = aw \times 10^{(A/(T+273.16)+B)}$$

where:

- aw = Water activity
- A,B = Coefficients (average/oil-specific)
- T = Temperature (°C)

Generally, measurements with MMT330 give accuracy better than 10 % of the reading. If additional accuracy is needed, see section Conversion Model with Oil-specific Coefficients on page 140.

### NOTE

The internal calculation in ppm conversion uses  $a_w$  also when only %RS output is selected when ordering MMT330.

To convert %RS to  $a_w$ , divide the %RS quantity by 100:

$$a_w = (\%RS / 100)$$

## Conversion Model with Oil-specific Coefficients

For additional accuracy, oil-specific conversion model can be used both for mineral and silicon based oils. An oil sample has to be sent to Vaisala for modelling. As a result, the specific coefficients (A and B, see formula 1) for the transformer oil are determined by Vaisala. For additional information, please contact Vaisala.

The determined coefficients of the transformer oil can be programmed to the MMT330 by Vaisala or by a user according to the instructions presented in this chapter.

**NOTE**

Conversion Model With Oil-specific Coefficients is always needed for **silicone based oils**.

## Setting Oil Coefficients Using Serial Line

If the ppm conversion and oil-specific coefficients have been programmed at Vaisala, the user does not have to set the conversion coefficients.

If a user has defined the coefficients or separately received from Vaisala the oil-specific coefficients A and B, related to the user's own oil type, the coefficients can be set to the software of MMT330 by using a serial bus or through an RS 485/422 serial module or through keypad/display.

### OIL

Use the serial line command OIL to set oil-specific parameters for ppm conversion.

Example:

```
>oil
Oil[0]      : -1662.6999 ?
Oil[1]      : 7.3694 ?
>
```

where

Oil [0] corresponds to parameter A  
Oil [1] corresponds to parameter B

## Using Display/Keypad

1. Press any of the arrow buttons to open the **Main Menu**.
2. Select **Measuring** by pressing the ► arrow button.
3. Select **Oil coefficients** by pressing the ► arrow button.
4. Press **SET**. Set the upper value A by using the ▲ ▼ buttons. Confirm by pressing **OK**.
5. Use the ▼ button to choose B. Press **SET**. Set the lower value B by using the ▲ ▼ buttons. Confirm by pressing **OK**.
6. Press **EXIT** to return to the basic display.

## Determination of Oil-Specific Coefficients

The equation of the ppm calculation is:

$$\text{ppm} = \text{aw} * 10^{(B+A/T)}$$

With the following procedure the coefficients A and B can be defined for the equation:

$$\text{LOG}(\text{PPM}_{\text{sat}}) = B + A/T$$

Equipment needed:

- Apparatus for determining water content ( for example, coulometric titrator and e.g. magnetic stirrer.)
- Oil test station:
  - a temperature test chamber
  - for example, a conical flask (1L) sealed by PTFE stopper with an inlet for a moisture probe
  - MMT330 by Vaisala
  - magnetic stirrer.

Procedure:

1. Define the water content of the oil sample with the titration. Use the oil moisture level that is close to real conditions in the process.
2. Measure the water activity of this sample with MMT330 at two temperatures that differ at least 20 °C. Follow the measurement stabilization illustrated by the graph.

### NOTE

The sample has to be sealed very carefully. If the sample is in contact with ambient air, its water content will be affected.

**NOTE**

If the oil sample is very dry and the temperatures are close to each other, it may cause inaccuracy to the calculation model. In order to get the best possible performance it is recommended to use oil conditions that represent real conditions in application. Recommended values for sample are  $a_w$  approx. 0.5 at 20 °C.

3. Define the correlation between  $a_w$ , T and PPM (w/w) from the measured values. Calculate A and B according to the following example.

$$A = \frac{\text{LOG}(PPM_{sat}[T2]) - \text{LOG}(PPM_{sat}[T1])}{1/(T2) - 1/(T1)}$$

$$B = \text{LOG}(PPM_{sat}[T1]) - A/T1$$

Example:

measured water content 213 ppm

T (°C)	$a_w$	ppm <sub>saturation</sub>
24.1	0.478	213/0.478 = 445.6067
57.6	0.188	213/0.188 = 1132.979

$$A = (\text{LOG}(1132.98) - \text{LOG}(445.607)) / (1/(57.6 + 273.16) - 1/(24.1 + 273.16)) = -1189.4581$$

$$B = \text{LOG}(445.607) - (-1189.4581) / (24.1 + 273.16) = 6.6503583$$

Assumptions:

The isotherm of water activity versus water concentration is linear and the solubility curve has the form of the given equation.



# CHAPTER 7

## MAINTENANCE

This chapter provides information that is needed in basic maintenance of MMT330.

### Periodic Maintenance

#### Cleaning

Clean the transmitter enclosure with a soft, lint-free cloth moistened with mild detergent.

Clean the sensor before storing the MMT330 probe and before calibration. For cleaning of the probe you need instrument air and heptane (C<sub>7</sub>H<sub>16</sub>) liquid. Dry with instrument air to prevent oxidation of the oil on the sensor. The oxidation of the oil on the sensor can cause extended response times or drifting.

1. Blow the probe with instrument air (with filter attached) to remove the remains of the oil.
2. Immerse the probe into heptane liquid and rinse out the oil (for 1 minute maximum).
3. Dry the probe with instrument air. In case you are going to calibrate the probe, remove the filter and dry the sensor with instrument air. Check that the sensor looks clean.

#### Changing the Probe Filter

1. Turn the filter counter-clockwise to loosen it.
2. Remove the filter from the probe. Be careful not to touch the sensor with the filter. Without the filter in place, the sensor is easily damaged – handle the probe carefully.
3. Install a new filter on the probe. When using the stainless steel filter, take care to tighten it properly (recommended force 5 Nm).

New filters can be ordered from Vaisala, see section Spare Parts and Accessories on page 164.

## Changing the Sensor

The user can change HUMICAP® 180L2 sensors. Changing the sensor should be considered corrective maintenance, and it is not necessary in normal operation. If the accuracy of the transmitter does not seem to be within specification, it is more likely that the transmitter is in need of calibration and adjustment, and not sensor replacement. Refer to chapter Calibration and Adjustment on page 149.

1. Remove the filter from the probe. See the instructions in section Changing the Probe Filter on page 143.
2. Remove the damaged sensor and insert a new one. Handle the new sensor by the plastic socket. **DO NOT TOUCH THE SENSOR PLATE.**
3. Perform a calibration and adjustment as instructed in section Relative Humidity Adjustment after Sensor Change on page 154.
4. Install a new filter on the probe. When using the stainless steel filter, take care to tighten the filter properly (recommended force 5 Nm).

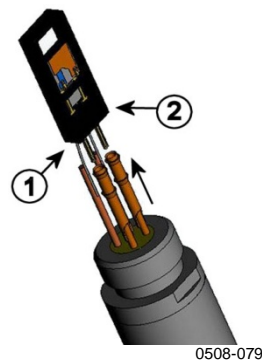

**Figure 67** Changing the Sensor

The following numbers refer to Figure 67 above:

- 1 = Pull out the sensor
- 2 = Plastic socket

## Error States

In error state the affected quantities are not measured and the output is shown as follows:

- Analog channel outputs 0 mA or 0 V (you can use the serial line command **AERR** or display/keypad to change this fault indication value, see section Analog Output Fault Indication Setting on page 120.)
- Serial port outputs stars "\*\*\*" instead of measurement data
- Display shows "----" instead of measurement data
- Cover LED is blinking
- Optional display: error indicator is lit.

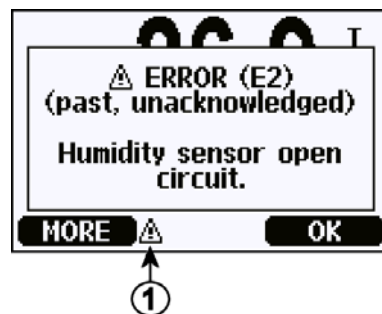

1103-068

**Figure 68 Error Indicator and Error Message**

The following number refers to Figure 68 above:

1 = Error indicator

The error indicator disappears when the error state is over and you have checked the error message. Press the **INFO** button to display the error message.

You can also check the error message via the serial interface by using the command **ERRS**. In case of constant error, please contact Vaisala; see section Technical Support on page 147.

**Table 30 Error Messages**

<b>Error Code</b>	<b>Error Message</b>	<b>Action</b>
E0	Humidity sensor measurement malfunction.	Check the integrity of the humidity probe and the probe cable. Clean the probe from dirt, water, ice or other contaminants.
E1	Humidity sensor short circuit	
E2	Humidity sensor open circuit	
E3	Temperature sensor open circuit.	Check the integrity of the humidity probe and the probe cable.
E4	Temperature sensor short circuit.	
E5	Temperature measurement malfunction	Check the integrity of the humidity probe and the probe cables. Clean the probes from dirt, water, ice or other contaminants.
E6	Temperature sensor current leak.	
E7	Internal ADC read error	Internal transmitter failure. Remove the transmitter and return the faulty unit to Vaisala Service.
E9	Checksum error in the internal configuration memory	Internal transmitter failure. Remove the transmitter and return the faulty unit to Vaisala Service.
E10	Internal EEPROM read error	
E11	Internal EEPROM write error	
E12 ... E13	Add-on module 1 (or 2) connection failure	Turn off the power and check the module connection. Turn on the power.
E14	Device internal temperature out of range	Ensure that the operating temperature is within the valid range.
E15	Internal RAM memory or software checksum error	Internal transmitter failure. Remove the transmitter and return the faulty unit to Vaisala Service.
E18	Internal ADC reference voltage out of range	Internal transmitter failure. Remove the transmitter and return the faulty unit to Vaisala Service.
E19	Internal analog output reference voltage out of range	
E20 ... E22	Configuration switches for analog output 1/2/3 set incorrectly	Check and re-set the switches, see Figure 58 on page 116 and Figure 30 on page 53.
E24 ... E25	Internal error in add-on module 1 (or 2)	Disconnect the power and check the module connection.
E26	Communication module installed in incorrect add-on module slot	Disconnect the power and change the communication module to another module slot.
E28 ... E29	Unknown/incompatible module installed in add-on module slot 1(or 2)	Ensure that the module is compatible with the MMT330.
E30	Internal analog voltage out of range	Internal transmitter failure. Remove the transmitter and return the faulty unit to Vaisala Service.
E31	Internal system voltage out of range	Check that the supply voltage is correct and the power supply can provide enough power for the instrument.

## Technical Support

For technical questions, contact the Vaisala technical support by e-mail at [helpdesk@vaisala.com](mailto:helpdesk@vaisala.com). Provide at least the following supporting information:

- Name and model of the product in question
- Serial number of the product
- Name and location of the installation site
- Name and contact information of a technically competent person who can provide further information on the problem

For contact information of Vaisala Service Centers, see [www.vaisala.com/servicecenters](http://www.vaisala.com/servicecenters).

This page intentionally left blank.

## CHAPTER 8

# CALIBRATION AND ADJUSTMENT

This chapter provides information that is needed in calibration and adjustment of the product.

The MMT330 is fully calibrated and adjusted as shipped from factory. The calibration interval depends on the application. When measuring moisture in transformer oil, the recommended calibration interval is 3 years. It is recommended that calibration is done always when there is a reason to believe that the device is not within the accuracy specifications.

The user can calibrate the MMT330 or send it to Vaisala for calibration. For contact information of Vaisala Service Centers, see [www.vaisala.com/servicecenters](http://www.vaisala.com/servicecenters).

Calibration and adjustment is carried out either by using the push-keys on the motherboard, through the serial port or with the optional display/keypad.

**NOTE**

The moisture in oil measurements are calibrated by performing a relative humidity (RH) calibration using reference gases. See Relative Humidity Adjustment on page 151.

Before the calibration the used sensor should be cleaned with instrument air to blow out existing oil or gently first flush with heptane (C<sub>7</sub>H<sub>16</sub>) and dry with instrument air to decrease response time.

**NOTE**

It is important to clean the sensor before calibration as an oily sensor can contaminate the salt bath and change the reference condition.

Vaisala HUMICAP® hand-held moisture and temperature in oil meter MM70 can also be used for calibration.

## Cleaning the Sensor

Clean the sensor before storing the MMT338 probe and before calibration. For cleaning of the probe you need instrument air and heptane liquid. Dry with instrument air to prevent oxidation of the oil on the sensor. The oxidation of the oil on the sensor can cause extended response times or drifting.

1. Blow the probe with instrument air (with the filter attached) to remove the remains of the oil.
2. Immerse the probe into heptane liquid and rinse out the oil.
3. Dry the probe with instrument air. In case you are going to calibrate the probe, remove the filter and dry the sensor with instrument air. Check that the sensor looks clean.

## Opening and Closing the Adjustment Mode

1. Open the transmitter cover. The buttons needed in adjustment are on the left-hand side of the motherboard.
2. Press the **ADJ** button to open the adjustment mode.
3. Press the **ADJ** button again to close the adjustment mode.

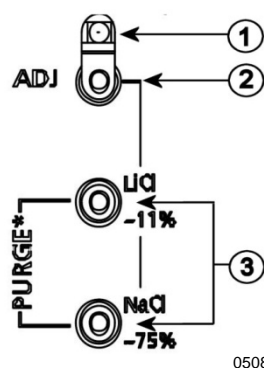

**Figure 69** Adjustment and Purge Buttons

The following numbers refer to Figure 69 above:

- |   |   |  |
|---|---|--|
| 1 | = | Indicator LED  |
| 2 | = | Adjustment button                                      |
| 3 | = | Salt adjustment buttons. Note: purge is not available. |

Adjustment menu is displayed only when **ADJ** button (on the motherboard inside the transmitter) is pressed.



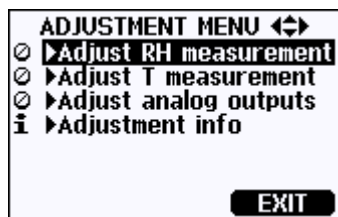

Figure 70 Adjustment Menu

Table 31 Indicator Led Functions

Indicator Led Function	Description
LED off	adjustment locked
LED on	adjustment available
LED blinking evenly	measurement not stabilized

## Relative Humidity Adjustment

### NOTE

The moisture in oil measurements are calibrated by performing a relative humidity (RH) calibration using reference gases.

## Using Push Buttons

A simple push-button adjustment is carried out by using two relative humidity references: 11 %RH (LiCl) and 75 %RH (NaCl).

### LiCl reference

1. Press the **ADJ** button (see Figure 69 on page 150) on the motherboard to open the adjustment mode. The indicator LED starts flashing.
2. Remove the filter from the probe and insert the probe into a measurement hole of the 11 %RH (LiCl) in the humidity calibrator HMK15. Use the adapter fitting for the MMT332, MMT337 and MMT338 probes.
3. Wait at least 30 minutes for the sensor to stabilize (the indicator LED is lit continuously). Adjustment cannot be done if the conditions are not stabilized (indicator LED is flashing).
4. When the indicator LED is lit continuously press the button LiCl-11% to adjust the 11 %RH condition. After adjustment transmitter returns to normal operation mode (indicator LED is unlit).

### NaCl reference

5. When adjusting in the second reference 75 %RH, press the **ADJ** button to open the adjustment mode. The indicator LED starts flashing.

6. Insert the probe into a 75 %RH (NaCl) reference chamber of the humidity calibrator HMK15. Use the adapter fitting for the MMT332, MMT337 and MMT338 probes.
7. Wait at least 30 minutes for the sensor to stabilize (the indicator LED is lit continuously). Adjustment cannot be done if the conditions are not stabilized (indicator LED is flashing).
8. Press the button **NaCl 75 %** to adjust the 75 %RH condition. After adjustment transmitter returns to normal operation mode (indicator LED is unlit).

## Using Display/Keypad

Note that the difference between the two humidity references must be at least 50 %RH.

1. Press the **ADJ** button (opens the **ADJUSTMENT MENU**).
2. Select **Adjust RH measurement**, press **▶** button.
3. Select **1-point/ 2-point adjustment**, press **START**.
4. Select the reference as guided by the display, press **SELECT**.

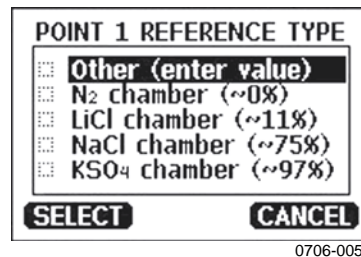

**Figure 71** Selecting Point 1 Reference Type

5. Remove the filter from the probe and insert the probe into a measurement hole of the dry end reference chamber (for example, LiCl: 11 %RH in the humidity calibrator HMK15.) Use the adapter fitting for the MMT332, MMT337 and MMT338 probes.
6. Wait at least 30 minutes for the sensor to stabilize. Follow the stabilization from the **GRAPH** display.
7. Press **READY** when stabilized. If you have chosen the **Other** reference value, enter now the reference value by using the arrow keys.

When carrying out the 2-point adjustment proceed to the next adjustment point and carry out the procedure as described in the previous steps.

8. Press **YES** to confirm the adjustment. Press **OK** to return to the adjustment menu.
9. Press **EXIT** to close the adjustment mode and return to the basic display. Before closing the adjustment mode, feed the adjustment

information into the device, see section Feeding Adjustment Information on page 158.

## Using Serial Line

Note that the difference between the two humidity references must be at least 50 %RH.

1. Connect the MMT330 to a PC. See section Serial Line Communication on page 78. Open a terminal program.
2. Press the **ADJ** button.
3. Remove the filter from the probe and insert the probe into a measurement hole of the dry end reference chamber (for example, LiCl: 11 %RH in the humidity calibrator HMK15). Use the adapter fitting for the MMT332, MMT337 and MMT338 probes.
4. Enter the **CRH** command and press **ENTER**.

### CRH

5. Wait at least 30 minutes for the sensor to stabilize.
6. Type **C** and press **ENTER** a few times to check if the reading is stabilized.
7. When the reading is stabilized, give the reference humidity after the question mark and press **ENTER**.

```
>crh  
  
RH :    11.25  Ref1 ? c  
RH :    11.25  Ref1 ? c  
RH :    11.25  Ref1 ? c  
RH :    11.24  Ref1 ? c  
RH :    11.24  Ref1 ? 11.3  
Press any key when ready ...
```

8. Now the device is waiting for the high end reference. Insert the probe into a measurement hole of the high end reference chamber (for example, NaCl: 75 %RH chamber in the humidity calibrator HMK15). Use the adapter fitting for the MMT332, MMT337 and MMT338 probes. Press any key when ready.
9. Let the probe stabilize for about 30 minutes. You can follow the stabilization by typing **C** and pressing **ENTER**.
10. When stabilized, type the high end reference value after the question mark and press **ENTER**.

```
>crh  
  
RH :    11.25  Ref1 ? c  
RH :    11.24  Ref1 ? c  
RH :    11.24  Ref1 ? 11.3
```

```
Press any key when ready ...
```

```
RH : 75.45 Ref2 ? c
RH : 75.57 Ref2 ? c
RH : 75.55 Ref2 ? c
RH : 75.59 Ref2 ? 75.5
OK
>
```

11. **OK** indicates that the adjustment has succeeded and the new calibration coefficients are calculated and stored. Enter the adjustment information (date and text) to the memory of the transmitter, see the commands **CTEXT** and **CDATE**.
12. Press the **ADJ** button on the motherboard to close the adjustment mode.
13. Take the probe out of the reference conditions and replace the filter.

## Relative Humidity Adjustment after Sensor Change

### Using Display/Keypad

When using the optional display/keypad, follow the instructions in section Using Display/Keypad on page 152 but select **Adj. for new RH sensor** (instead of **1-point/ 2-point adjustment**).

### Using Serial Line

After sensor change, carry out the procedure as described in previous sections. Just replace the **CRH** command with the **FCRH** command.

#### FCRH

Example:

```
>fcrh
RH : 1.82 1. ref ? 0
Press any key when ready...
RH : 74.22 2. ref ? 75
OK
>
```

The OK indicates that the calibration has succeeded.

# Temperature Adjustment

## Using Display/Keypad

1. Press the **ADJ** button on the motherboard to open the **ADJUSTMENT MENU**. If using a warmed probe for measuring, probe heating will be interrupted when **ADJ** key is pressed. Wait some time for the probe to reach ambient temperature.
2. Select **► Adjust T measurement**, press **►** key.
3. Select **1-point/ 2-point adjustment**, press **START**.
4. Remove the filter from the probe and insert the probe into the reference temperature.
5. Wait at least 30 minutes for the sensor to stabilize. Follow the stabilization from the **GRAPH** display.
6. Press **READY** when stabilized. Give the reference temperature using the arrow keys.  

When carrying out the 2-point adjustment, proceed to the next adjustment point and carry out the procedure as described in the previous item. Note that the difference between the two temperature references must be at least 30 °C.
7. Press **OK**. Press **YES** to confirm the adjustment.
8. Press **OK** to return to the adjustment menu.
9. Press **EXIT** to close the adjustment mode and return to the basic display.

## Using Serial Line

1. Press the **ADJ** key on the motherboard to open the adjustment mode.
2. Remove the probe filter and insert the probe into the reference temperature.
3. Enter the command **CT** and press **ENTER**.
4. Type **C** and press **ENTER** a few times to check if the reading is stabilized. Let the reading stabilize, give the reference temperature after the question mark and press **ENTER** three times.

When having another reference temperature (2-point calibration) press **ENTER** only twice and insert the probe to the second reference. When the reading is stabilized, give the second reference temperature after the question mark and press **ENTER**. Note that the difference between the two temperature references must be at least 30 °C.

Example (one-point adjustment):

```
>ct
T : 16.06 Ref1 ? c
T : 16.06 Ref1 ? c
T : 16.06 Ref1 ? c
T : 16.06 Ref1 ? c
T : 16.06 Ref1 ? c
T : 16.06 Ref1 ? 16.0
Press any key when ready ...
T : 16.06 Ref2 ?
OK
>
```

5. **OK** indicates that the calibration has succeeded. Give the calibration information (date and text) to the transmitter's memory; see the serial commands **CTEXT** and **CDATE**.
6. Press the **ADJ** button on the motherboard to close the adjustment mode.
7. Take the probe out of the reference conditions and replace the filter.

## Analog Output Adjustment

In the analog output calibration the analog output is forced to the following values:

- Current output: 2 mA and 18 mA
- Voltage output: 10 % and 90 % of the range

Connect MMT330 to a calibrated current/voltage meter in order to measure either current or voltage depending on the selected output type.

### Using Display/Keypad

1. Press the **ADJ** button to open the **ADJUSTMENT MENU**.
2. Select **► Adjust analog outputs**, press **►** key.
3. Select the output to be adjusted **Adjust analog output 1/2**, press **START**.
4. Measure the first analog output value with a multimeter. Give the measured value by using the arrow buttons. Press **OK**.
5. Measure the second analog output value with a multimeter. Give the measured value by using the arrow buttons. Press **OK**.
6. Press **OK** to return to the adjustment menu.
7. Press **EXIT** to close the adjustment mode and to return to the basic display.

### Using Serial Line

Enter the **ACAL** command and type the multimeter reading for each case. Continue by pressing **ENTER**.

#### ACAL

Example (current outputs):

```
>acal
Ch1    I1    (mA) ?    2.046
Ch1    I2    (mA) ?    18.087
Ch2    I1    (mA) ?    2.036
Ch2    I2    (mA) ?    18.071
>
```

## Feeding Adjustment Information

This information is shown on the device information fields (see section Device Information on page 104.)

### Using Display/Keypad

1. If you are not in the adjustment menu, press the **ADJ** button on the motherboard (opens the **ADJUSTMENT MENU**).
2. Select **► Adjustment info**, press the arrow **►** button.
3. Select **Date**, press **SET**. Give the date by using the arrow buttons. Press **OK**.
4. Select **i**, press **SET**. Enter information text including 17 characters at maximum by using the arrow buttons. Press **OK**.
5. Press **EXIT** to return to the basic display.

### Using Serial Line

#### CTEXT

Use the CTEXT command to enter text to the adjustment information field.

Example:

```
>ctext
Adjust. info   : (not set) ? HMK15
>
```

#### CDATE

Use the CDATE command to enter date to adjustment information field. Set the adjustment date in format YYYY-MM-DD.

Example:

```
>cdate
Adjust. date   : (not set) ? 2004-05-21
>
```



# CHAPTER 9

## TECHNICAL DATA

This chapter provides the technical data of the product.

### Specifications

#### Performance

##### Water Activity and Relative Saturation

Water activity / Relative saturation

Measurement range 0 ... 1  $a_w$  / 0 ... 100 %RS

Accuracy (including non-linearity, hysteresis and repeatability)

0 ... 0.9  $a_w$  / 0 ... 90 %RS  $\pm 0.02 a_w / \pm 2$  %RS

0.9 ... 1  $a_w$  / 90 ... 100 %RS /  $\pm 0.03 a_w / \pm 3$  %RS

Response time (90%) at +20 °C

in still oil (with stainless steel filter) 10 min.

Sensor

HUMICAP®

##### Temperature

Measurement range

MMT332 -40 ... +180 °C (-40 ... +356 °F)

MMT337 -40 ... +180 °C (-40 ... +356 °F)

MMT338 -40 ... +180 °C (-40 ... +356 °F)

Temperature sensor

Pt100 RTD Class F0.1 IEC 60751

Accuracy at +20 °C (+68 °F)

$\pm 0.2$  °C

Accuracy over temperature range (see graph below):

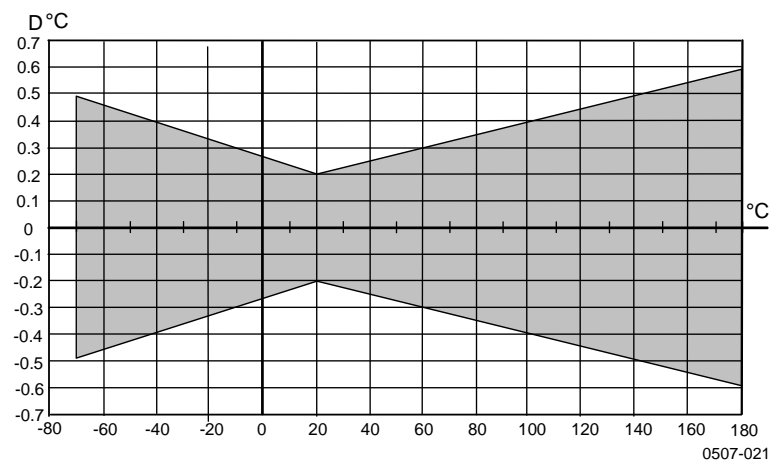

**Figure 72 Accuracy over Temperature Range**

## Operating Environment

Operating temperature	
for probes	same as measurement ranges
for transmitter body	-40 ... +60 °C (40 ... +140°F)
with display	0 ... +60 °C (+32 ... +140°F)
Storage temperature	
without display	-55 ... +80 °C (-67 ... +176 °F)
with display	-40 ... +80 °C (-40 ... +176 °F)
Pressure range for probes	See probe specifications
Electromagnetic compatibility	EN61326-1: Electrical equipment for measurement, control, and laboratory use – EMC requirements – for use in industrial locations

## Probe Specifications

### MMT332

Pressure range	up to 250 bar / 3625 psia
Probe diameter	12 mm / 0.5 inch
Installation	
Flange	36 mm / 1.4 inch

### MMT337

Pressure range	0 ... 10 bar / 0 ... 145 psia
Mechanical durability	up to 10 bar / 145 psia
Probe diameter	12 mm / 0.5 inch
Installation	
Fitting Body	R 3/8" ISO
Fitting Body	NPT 1/2"

### MMT338

Pressure range	0 ... 40 bar / 0 ... 580 psia
Mechanical durability	up to 40 bar / 580 psia
Adjustable length	41 ... 149/371 mm / 1.61 ... 5.87/14.6 inch
Installation	
Fitting Body	R1/2" ISO
Fitting Body	NPT 1/2"
Ball Valve Set	BALLVALVE-1
Sampling Cell	DMT242SC2

## Inputs and Outputs

Operating voltage	10 ... 35 VDC, 24 VAC
with optional power supply module	100 ... 240 VAC, 50/60 Hz
Power consumption @ 20 °C (U <sub>in</sub> 24VDC)	
RS-232	max 25 mA
U <sub>out</sub> 2 x 0 ... 1V / 0 ... 5V / 0 ... 10V	max 25 mA
I <sub>out</sub> 2 x 0 ... 20 mA	max 60 mA
display and backlight	+ 20 mA
Analog outputs (2 standard, 3rd optional)	
current output	0 ... 20 mA, 4 ... 20 mA
voltage output	0 ... 1 V, 0 ... 5 V, 0 ... 10 V
Accuracy of analog outputs at 20 °C	± 0.05 % full scale
Temperature dependence of the analog outputs	± 0.005 %/°C full scale
External loads	
current outputs	R <sub>L</sub> < 500 ohm
0 ... 1V output	R <sub>L</sub> > 2 kohm
0 ... 5V and 0... 10V outputs	R <sub>L</sub> > 10 kohm
Wire size	0.5 ... 2.5 mm <sup>2</sup> (AWG 20 ... 14)
	stranded wires recommended
Digital outputs	RS-232
	RS-422/485 (optional)
	LAN (optional)
	WLAN (optional)
Protocols	ASCII commands
	Modbus RTU
	Modbus TCP
Relay outputs (optional)	0.5 A, 250 VAC, SPDT
Display	(optional)
	LCD with backlight, graphic
	trend display of any parameter
Display menu languages	Chinese, English, Finnish,
	French, German, Japanese,
	Russian, Spanish, Swedish

## Mechanics

Cable bushing	M20x1.5 for cable diameter
	8 ... 11mm/0.31 ... 0.43"
Conduit fitting	1/2" NPT
Interface cable connector (optional)	M12 series 8-pin (male)
option 1	with plug (female) with 5 m /
	16.4 ft black cable
option 2	with plug (female) with screw
	terminals
Probe cable diameter	5.5 mm
Probe tube material	AISI 316L
Housing material	G-AlSi 10 Mg (DIN 1725)
Housing classification	IP 65 (NEMA 4X)
Transmitter weight (with probe, cable, and modules)	1.0 ... 3.0 kg (2.2 ... 6.6 lb)

**Table 32 Standard Probe Cable Lengths and Approximate Transmitter Weight (in kg/lb)**

Probe Type	Probe Cable Length				
	2 m	5 m	10 m	15 m	20 m
MMT332	1.1/2.4	1.2/2.6	1.5/3.3	-	-
MMT337	1.2/2.6	1.3/2.9	1.5/3.3	-	2.1/4.5
MMT338 232 mm	1.3/2.9	1.5/3.3	1.7/3.7	-	-
MMT338 454 mm	1.4/3.1	1.6/3.5	1.9/4.2	2.2/4.9	2.5/5.6

## Technical Specifications of Optional Modules

### Power Supply Module

Operating voltage	100 ... 240 VAC 50/60 Hz
Connections	screw terminals for 0.5 ... 2.5 mm <sup>2</sup> wire (AWG 20...14) for 8...11 mm diameter cable
Bushing	for 8...11 mm diameter cable
Operating temperature	-40 ... +60 °C (-40 ... +140 °F)
Storage temperature	-40 ... +70 °C (-40 ... +158 °F)
UL file number	E249387

### Analog Output Module

Outputs	0 ... 20 mA, 4 ... 20 mA, 0 ... 1 V, 0 ... 5 V, 0 ... 10 V
Operating temperature range	-40 ... +60 °C (-40 ... +140 °F)
Power consumption	
$U_{out}$ 0 ... 1 V	max 30 mA
$U_{out}$ 0 ... 5V/0 ... 10V	max 30 mA
$I_{out}$ 0 ... 20 mA	max 60 mA
External loads	
current outputs	$R_L < 500$ ohms
Max load + cable loop resistance	540 ohms
0 ... 1 V	$R_L > 2000$ ohms
0 ... 5 V and 0... 10 V	$R_L > 10\,000$ ohms
Storage temperature range	-55 ... +80 °C (-67 ... +176 °F)
3-pole screw terminal	
max wire size	1.5 mm <sup>2</sup> (AWG16)

## Relay Module

Operating temperature range	-40 ... +60 °C (-40...+140 °F)
Operating pressure range	500 ... 1300 mmHg
Power consumption @24 V	max 30 mA
Contacts SPDT (change over), for example, Contact arrangement Form C	
I <sub>max</sub>	0.5 A 250 VAC
I <sub>max</sub>	0.5 A 30 VDC
Safety standard for the relay component	IEC60950 UL1950
Storage temperature range	-55 ... +80 °C (-67...+176 °F)
3-pole screw terminal / relay max wire size	2.5 mm <sup>2</sup> (AWG14)

## RS-485 Module

Operating temperature range	-40 ... +60 °C (-40 ... +140 °F)
Operating modes	2-wire (1-pair) half duplex 4-wire (2-pair) full duplex
Operating speed max	115.2 kbaud
Bus isolation	300VDC
Power consumption @ 24V	max 50 mA
External loads standard loads	32 RL > 10kohm
Storage temperature range	-55 ... +80 °C (-67 ... +176 °F)
Max wire size	1.5 mm <sup>2</sup> (AWG16)

## LAN Interface Module

Operating temperature range	-40 ... +60 °C (-40 ... +140 °F)
Storage temperature range	-40 ... +85 °C (-40 ... +185 °F)
Operating humidity range	5 ... 95 %RH
Power consumption @ 24V	max 60 mA
Ethernet type	10BASE-T 100BASE-TX
Connector	8P8C (RJ45)
IPv4 address assignment	DHCP (automatic), static
Protocols	Telnet, Modbus TCP
Max number of Telnet/Modbus clients	1

## WLAN Interface Module

Operating temperature range	-20 ... +60 °C (-4 ... +140 °F)
Storage temperature range	-40 ... +85 °C (-40 ... +185 °F)
Operating humidity range	5 ... 95 %RH
Power consumption @ 24V	max 80 mA
Supported standards	802.11b
Connector	RP-SMA
IPv4 address assignment	DHCP (automatic), static
Protocols	Telnet, Modbus TCP
Max number of Telnet/Modbus clients	1
Security	WEP 64/128, WPA2/802.11i

## Data Logger Module

Operating temperature range	-40 ... +60 °C (-40 ... +140 °F)
Storage temperature range	-55 ... +80 °C (-67 ... +176 °F)
Power consumption @ 24V	max 10 mA
Logged parameters	up to four with trend/min/max values for each
Logging interval	10 s (fixed)
Maximum logging period	4 years 5 months
Logged points	13.7 million points / parameter
Accuracy of the clock	better than $\pm 2$ min/year
Battery lifetime	
at -40 ... +30 °C (-40 ... +86 °F)	7 years
at +30 ... +60 °C (+86 ... +140 °F)	5 years

## Spare Parts and Accessories



Information on spare parts, accessories, and calibration products is available online at [www.vaisala.com](http://www.vaisala.com) and [store.vaisala.com](http://store.vaisala.com).

**Table 33 Spare Parts and Accessories**

Description	Order Code
<b>MODULES</b>	
Relay module	RELAY-1
Analog Output Module	AOUT-1
Isolated RS485 Module	RS485-1
Power Supply Module	POWER-1
Galvanic Isolation Module	DCDC-1
<b>SENSORS</b>	
HUMICAP® 180L2	HUMICAP180L2
PT100 Sensor	10429SP
<b>FILTERS</b>	
Stainless Steel Filter	HM47453SP
Stainless Steel Grid (for applications with high flow speed, >1 m/s)	220752SP
<b>TRANSMITTER MOUNTING ACCESSORIES</b>	
Wall Mounting Kit	214829
Installation Kit for Pole or Pipeline	215108
Rain Shield with Installation Kit	215109
DIN Rail Clips with Installation Plate	215094
<b>PROBE MOUNTING ACCESSORIES</b>	
MMT332	
5 pcs O-ring Set Size 14.1x1.6	216026
MMT337	
Swagelok for 12mm Probe 3/8" ISO Thread	SWG12ISO38
Swagelok for 12mm Probe 1/2" ISO Thread	SWG12ISO12

<b>Description</b>	<b>Order Code</b>
Swagelok for 12mm Probe 1/2" NPT Thread MMT338	SWG12NPT12
Fitting Body ISO1/2 Solid Structure	DRW212076SP
Fitting Body NPT1/2 Solid Structure	NPTFITBODASP
Sampling Cell with Swagelok Connectors	DMT242SC2
Ball Valve ISO1/2 with Welding Joint	BALLVALVE-1
Manual Press	HM36854SP
Plug Kit (ISO 1/2)	218773
<b>CONNECTION CABLES</b>	
Serial Interface Cable	19446ZZ
USB-RJ45 Serial Interface Cable	219685
MI70 Connection Cable with RJ45 Connector	211339
<b>OUTPUT CABLES FOR 8-PIN CONNECTOR</b>	
Connection Cable 5m 8-pin M12 Female, Black	212142
Female Connector 8-pin M12 with Screw Terminals	212416
Male Connector 8-pin M12 with Cable and Adapter	214806SP
<b>CABLE BUSHINGS</b>	
Cable Gland M20x1.5 for 8...11mm Cable	214728SP
Cable Gland M20x1.5 for 11...14mm Cable	214729
Conduit Fitting M20x1.5 for NPT1/2 Conduit	214780SP
Dummy Plug M20x1.5	214672SP
<b>WINDOWS SOFTWARE</b>	
MI70 Link software with RS232 Service Cable	215005
MI70 Link software with USB Cable	219916
<b>OTHER</b>	
HMK15 Calibration Adapter for 12 mm Probes with >7 mm Sensor Pins	211302SP
Enclosure spare kit: hexagonal cover screws (4x) and hinge with attachment screws	238509

## Dimensions (mm/inch)

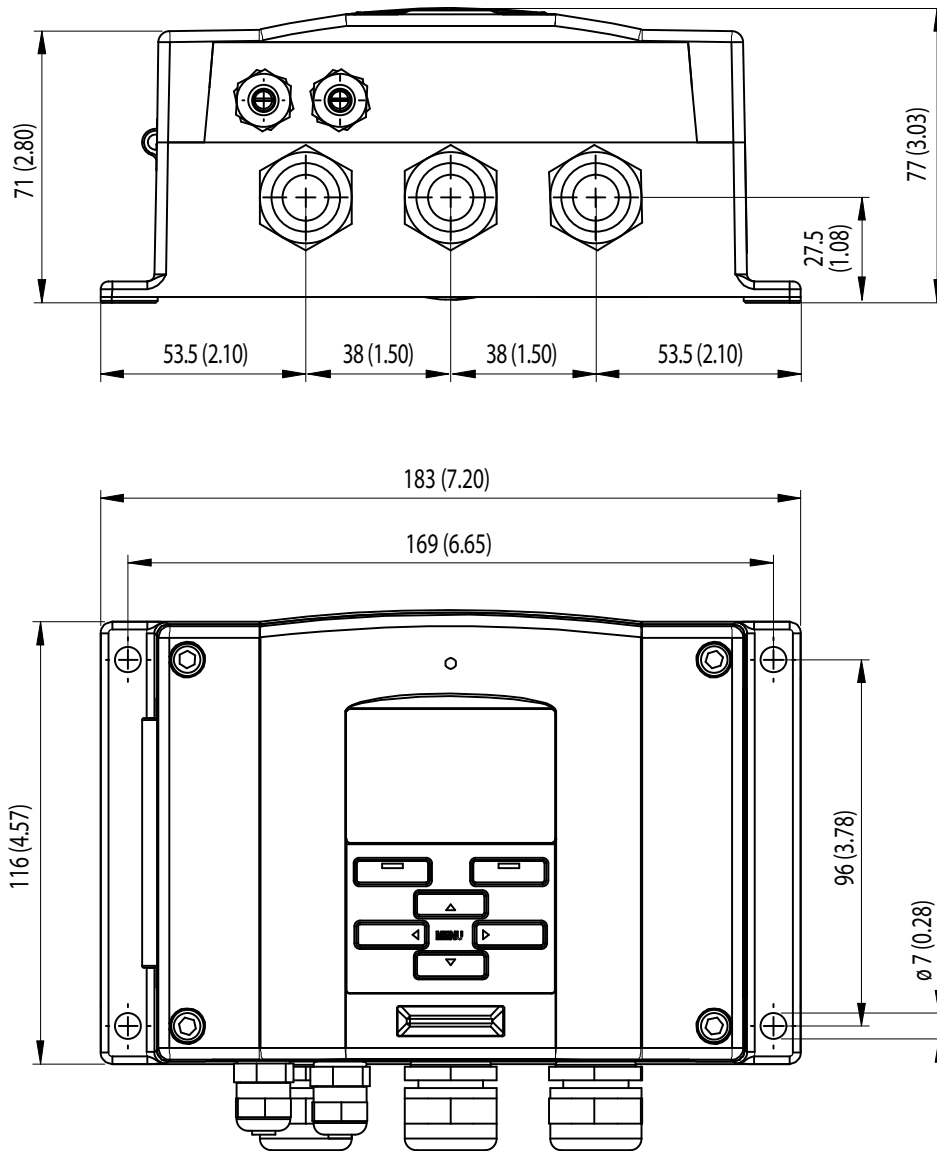

0506-035

**Figure 73** Transmitter Body Dimensions



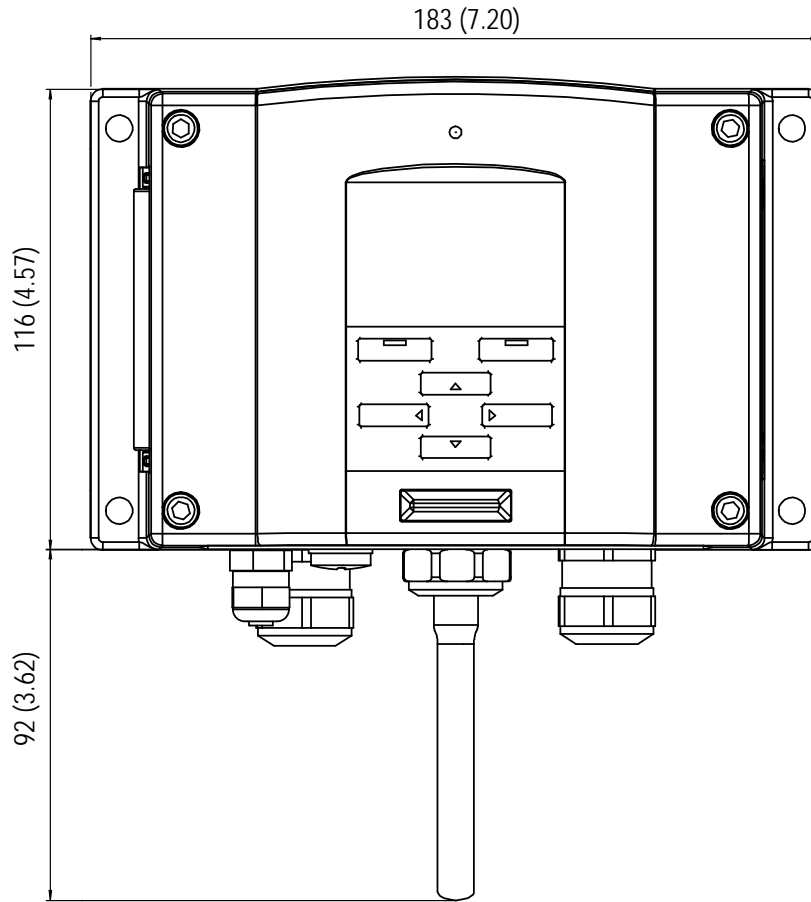

0804-035

**Figure 74 WLAN Antenna Dimensions**

# MMT332

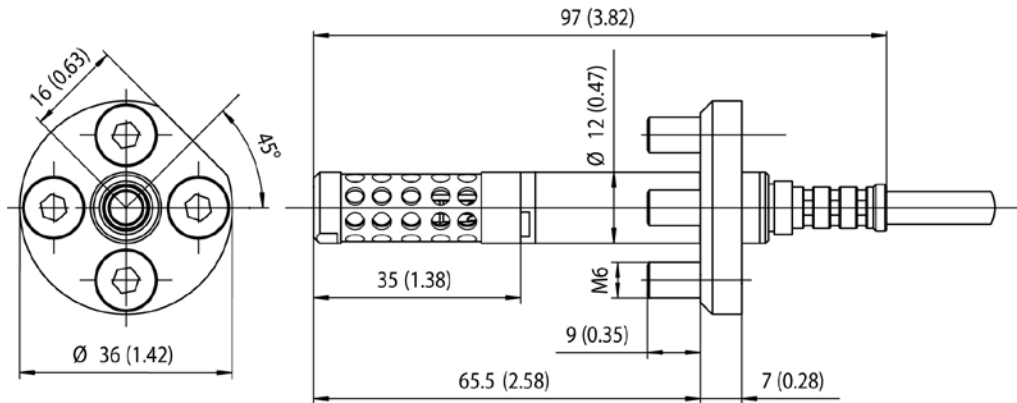

0509-149

Figure 75 MMT332 Probe Dimensions

# MMT337

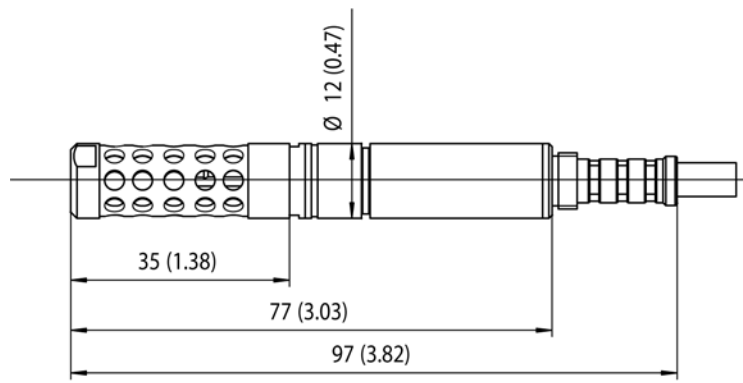

0509-146

Figure 76 MMT337 Probe Dimensions

## MMT337 with Swagelok Connector

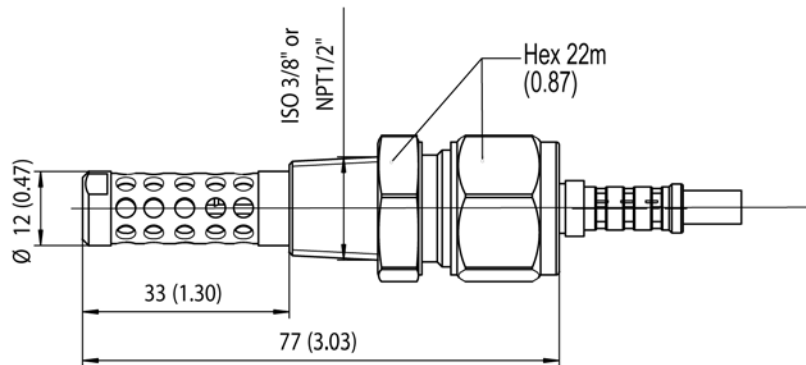

0509-148

**Figure 77** MMT337 Probe with (Optional) Swagelok Connector, Dimensions

## MMT338

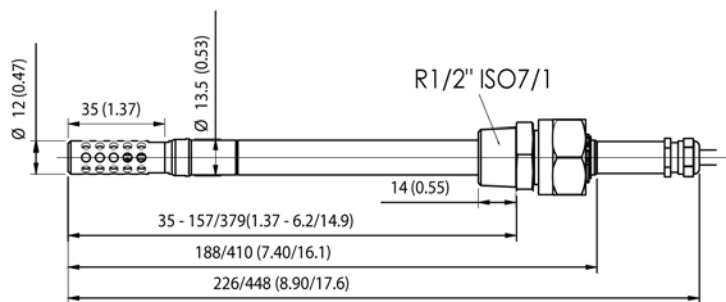

0509-145

**Figure 78** MMT338 Probe with Stainless Steel Filter (Oil Filter), Dimensions

This page intentionally left blank.

## APPENDIX A

# MODBUS REFERENCE

This appendix describes the Modbus functions and data of the transmitter.

## Function Codes

MMT330 supports all Modbus conformance class 0 and class 1 function codes defined in Open Modbus/TCP Specification, Release 1.0.

**Table 34 Supported Function Codes**

Function Code	Name	Notes
01 (0x01)	Read Coils	Class 1
02 (0x02)	Read Discrete Inputs	Class 1
03 (0x03)	Read Holding Registers	Class 0
04 (0x04)	Read Input Registers	Class 1
05 (0x05)	Write Single Coil	Class 1
06 (0x06)	Write Single Register	Class 1
07 (0x07)	Read Exception Status	Class 1
08 (0x08)	Diagnostics	
15 (0x0F)	Write Multiple Coils	Class 2
16 (0x10)	Write Multiple Registers	Class 0
22 (0x16)	Mask Write Register	Class 2
23 (0x17)	Read/Write Multiple Registers	Class 2
43 / 14 (0x2B / 0x0E)	Read Device Identification	

Class 0 function codes are enough to access all measurement data and configuration settings of the MMT330 transmitter. In addition, all class 1 and some class 2 commands are also supported giving better compatibility and allowing more efficient communication when needed.

Modbus diagnostic and device identification data can be read out only with the function codes dedicated for those purposes (08 and 43 / 14).

## Register Map

All data available via the Modbus interface is grouped in six contiguous blocks of registers as described in Table 35 below.

**Table 35 MMT330 Modbus Register Blocks**

Address	Data Format	Description
0001...0068	32-bit IEEE float	Measurement data (read-only)
0257...0290	16-bit signed integer	
0513...0517	Bit field	Status registers (read-only)
0769...0790	32-bit IEEE float	Configuration settings
1025...1035	16-bit signed integer	
1281...1288	Bit field	Configuration flags

The addresses are 1-based decimal Modbus data model addresses without the first digit (e.g. 0xxxx, 1xxxx, 3xxxx, or 4xxxx). Subtract 1 to get address field values used in Modbus Protocol Data Unit (PDU).

The register map is the same for all Modbus function codes. For example, function codes 03 and 04 return exactly same result, as do 01 and 02.

Function codes 01 and 02 return 0 if the corresponding register has value 0x0000 and 1 if the register is non-zero. Writing with function codes 05 or 15 effectively writes value 0x0000 or 0x0001 in the register(s).

## Data Encoding

All numeric values are available both in 32-bit IEEE floating point and 16-bit signed integer formats.

### 32-Bit Floating Point Format

Floating point values are represented in standard IEEE 32-bit floating point format. Least-significant 16 bits of floating point numbers are placed at the smaller Modbus address as specified in Open Modbus TCP Specification, Release 1.0. This is also known as “little-endian” or “Modicon” word order.

#### NOTE

Despite the specification, some Modbus masters may expect “big-endian” word order (most-significant word first). In such case, you must select “word-swapped” floating point format in your Modbus master for MMT330 Modbus registers.

A “quiet NaN” value is returned for unavailable values. Writing any NaN or infinite value is silently ignored. A quiet NaN is, for example, 0x7FC00000; however, the master should understand any NaN value.

**NOTE**

A complete 32-bit floating point value should be read and written in a single Modbus transaction (e.g. function codes 05, 06, and 22 do not have an effect on floating point values).

## 16-Bit Integer Format

16-bit integer values are scaled to include the necessary decimals (see corresponding register table for the scaling factor). Negative values (when applicable) are represented in 2's complement (65535 = -1, 65534 = -2, etc.).

**NOTE**

Measurement parameters with normally positive values (for example, 0 ... 1 aw) may occasionally return small negative values because of measurement inaccuracy. These negative values are returned as large 16-bit integer values (2's complement).

If the scaled value does not fit in the range 0...65535 (16-bit range), the value is "wrapped" to the range by adding or subtracting 65536 as many times as needed.

However, most of the measurement data values do not need any offset.

A zero 16-bit value is returned for unavailable values. There is no way to distinguish missing values from actual zero values if the zero value is included in the valid measurement range of the parameter.

**NOTE**

If your Modbus master supports 32-bit floating point values, always use them instead of 16-bit integer registers.

The use of 16-bit integer values is not recommended in critical applications because you cannot distinguish true zero values from zero values generated by measurement failures.

In addition to this, 2's complement makes negative values look like large positive values, which must be taken into account when utilizing the 16-bit register values.

When writing 16-bit values in configuration registers, they are always processed as signed integers in the range of -32768...+32767. You shall use the floating point registers to write values outside this 16-bit signed integer range. Maximum writable value is 32767 also for configuration registers that do not accept negative values.

## Measurement Data (Read-Only)

**Table 36 Measurement Data Registers**

Name	Float	Integer	Unit
T	0003...0004	0258 (x0.01)	°C
a <sub>w</sub>	0029...0030	0271 (x0.0001)	
%RS	0041...0042	0277 (x0.01)	%
H <sub>2</sub> O	0035...0036	0274 (x1)	ppm

Available measurements depend on the instrument configuration. Values may be unavailable also in case of device failure. Read status registers or exception status outputs to check for failures.

### NOTE

Only real-time data can be read from the instrument. Data that is recorded in the transmitter's memory (internal memory or data logger module) cannot be read through Modbus.

## Status Registers (Read-Only)

**Table 37 Status Registers**

Name	Address	Description
Fault status	0513	1 = No errors
Online status	0514	1 = Online data available
Error code (bits 15...0)	0516	Bit field that represents the error codes listed in Table 30 on page 146. Active errors are set to 1. For example, if bit 14 is set to 1, error code E14 is active.
Error code (bits 31...16)	0517	

Error information can be retrieved also with function code 08, sub-function 02.

### NOTE

Basic status information of the MMT330 transmitter is also available with the Read Exception Status function code 07. For details, see section Exception Status Outputs on page 175.

## Configuration Registers

Configuration parameter registers are used to configure the measurement. Writing out-of-range values is silently ignored.

**Table 38 Configuration Parameter Registers**

Name	Float	Integer	Valid Range
Oil-A	0777...0778	1029 (x0.01)	±99999.99
Oil-B	0779...0780	1030 (x0.0001)	±99.9999



Non-metric units are not available on Modbus. If they are needed, calculate the conversion outside the transmitter.

Configuration flags are used to select some basic options of the instrument and to manually start the sensor operations.

**Table 39 Configuration Flag Registers**

Name	Address	Description
Standard filtering on/off	1281	1 = Filtering on
Extended filtering on/off	1282	1 = Extended filtering on

Flags 1281 and 1282 are mutually exclusive.

Some of the configuration registers might not have an effect depending on the instrument model and configuration.

Other configuration settings are not usually needed and are not available using the Modbus interface. The service cable must be used to change other configuration settings if needed.

## Exception Status Outputs

Exception status outputs (read with function code 07) tell the summary of the MMT330 transmitter status as described in Table 40 below.

**Table 40 MMT330 Exception Status Outputs**

Output	Name	Description
0 (0x01)	Fault status	1 = No errors
1 (0x02)	Online status	1 = Online data available

Status information is available also with register access; see section Status Registers (Read-Only) on page 174.

## Diagnostic Sub-Functions

MMT330 supports some of the Modbus diagnostic functions described in the Modbus Application Protocol Specification V1.1b. These diagnostic functions are accessed with function code 08. See Table 41 below for details.

**Table 41 MMT330 Modbus Diagnostics**

Code	Sub-Function Name	Notes
00 (0x00)	Return Query Data	
01 (0x01)	Restart Communications Option	Cancels the "Listen Only" mode. Data field must be set to "00 00" for Restart Communications Option. Sub-Function 01 with data field "FF 00" is rejected.
02 (0x02)	Return Diagnostic Register	Non-zero if there are active transmitter errors.  For same error information, see status registers 0516 and 0517. The value of the Diagnostic Register is a logical OR of these two status registers.
04 (0x04)	Force Listen Only Mode	Puts device "off-line"
10 (0x0A)	Clear Counters and Diagnostic Register	Diagnostic Register cannot be cleared
11 (0x0B)	Return Bus Message Count	Total number of messages seen on the bus/interface
12 (0x0C)	Return Bus Communication Error Count	Number of messages with bad Modbus RTU CRC or Modbus TCP frame
13 (0x0D)	Return Bus Exception Error Count	Number of Modbus exception responses sent
14 (0x0E)	Return Slave Message Count	Number of Modbus messages processed
15 (0x0F)	Return Slave No Response Count	Number of Modbus messages received without sending a response. This happens for received broadcast messages (Modbus RTU only) or when MMT330 is in the "Listen Only" mode.

Although Modbus Diagnostics are standardized only for serial line devices, MMT330 supports the same diagnostic functions also on Modbus TCP.

### NOTE

Resetting, powering up the transmitter, or reselecting the Modbus mode (by serial command or with the user interface) resets all Modbus diagnostic counters and cancels any "Listen Only" mode.

## Device Identification Objects

MMT330 Modbus conforms to the extended identification level defined in the Modbus Application Protocol Specification V1.1b. Both stream access and individual access to the objects is supported.

**Table 42 MMT330 Modbus Device Identification**

Object Id	Object Name	Description
0x00	VendorName	"Vaisala"
0x01	ProductCode	Product code (e.g. "MMT330")
0x02	MajorMinorVersion	Software version (e.g. "5.10")
0x03	VendorUrl	"http://www.vaisala.com/"
0x04	ProductName	Product name of the instrument
0x80	SerialNumber	Serial number (e.g. "D0710040")
0x81	CalibrationDate	Date of the last calibration (e.g. "2011-02-07", empty if not available)
0x82	CalibrationText	Information text of the last calibration (empty if not available)

## Exception Responses

Exception responses from the transmitter are according to the Modbus Application Protocol Specification V1.1b.

**Table 43 MMT330 Modbus Exception Responses**

Code	Name	Reason
01	ILLEGAL FUNCTION	Unsupported function code
02	ILLEGAL DATA ADDRESS	Address out of valid ranges
03	ILLEGAL DATA VALUE	Otherwise invalid request

Accessing unavailable (unsupported or temporarily missing) registers inside ranges specified in Table 36 does not generate an exception. "Unavailable" value (a quiet NaN for floating point data or zero for integer data) is returned instead. An exception is generated only for any access outside the register blocks defined in section Register Map on page 172.





[www.vaisala.com](http://www.vaisala.com)

