



Features

High Accuracy and Stability

Accurate within ± 1.5 kPa across a pressure range of 15 to 115 kPa (4.43 to 34.96 in Hg). Long-term non-stability has been measured continuously indoors and in natural conditions (with sensors mounted inside a datalogger enclosure) for multiple sensors and is less than 0.5 % per year. Temperature effects on signal are less than 1 % across a wide temperature range (-20 to 50 C).

Low Power, Large Signal

Pressure sensor power requirement is approximately 35 mW (7 mA current draw at 5 V DC). Voltage output ranges from 0 to 5 V DC for a pressure range of 15 to 115 kPa.

Small Size

Sensor is small and lightweight enabling easy deployment within a datalogger enclosure, protecting the sensor from the elements.

Dimensions

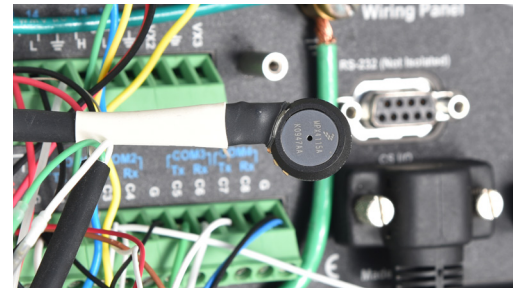
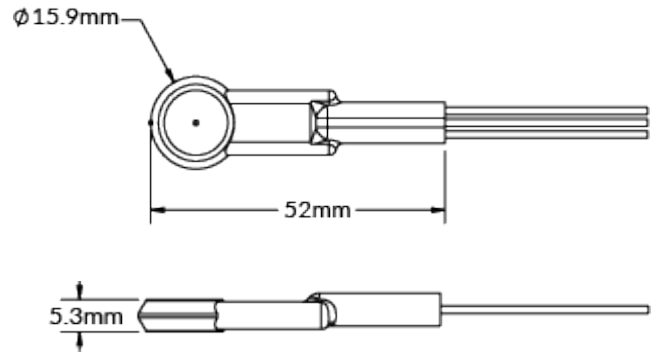

Product Specifications

SB-100	
Measurement Range	15 to 115 kPa (approximate)
Maximum Pressure Exposure	400 kPa (exposure beyond this limit may cause permanent damage to sensor)
Sensitivity	45.9 mV per kPa; 0.459 mV per 0.01 kPa (approximate)
Calibration Factor	0.0218 kPa per mV (generic slope; reciprocal of sensitivity) and 11.4 kPa (generic intercept)
Measurement Uncertainty	± 1.5 kPa (with generic calibration coefficients)
Measurement Repeatability	Less than 0.1 %
Non-linearity	Less than 1 %
Warm-up Time	20 ms
Response Time	1 ms
Temperature Response	Less than 0.002 % per C for temperatures greater than 0 C; -0.015 % per C for temperatures less than 0 C
Operating Environment	-40 to 80 C; 0 to 100 % relative humidity (non-condensing)
Input Voltage Requirement	5 V DC
Output Voltage Requirement	0 to 5 V DC
Current Draw	7 mA DC
Dimensions	16 mm diameter
Mass	5 g
Cable	12 cm pigtail
Warranty	4 years against defects in materials and workmanship