

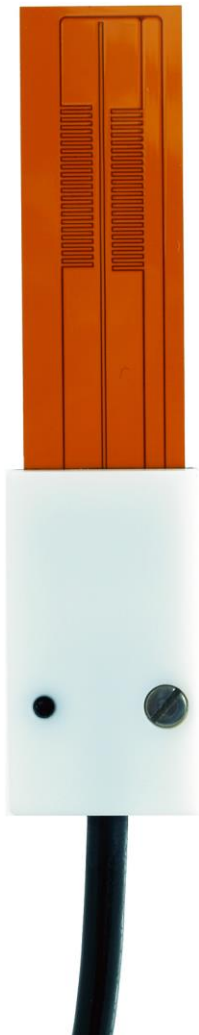

USER MANUAL **TP01**

Thermal properties sensor



Warning statements



Putting more than 2 Volt across the sensor wiring can lead to permanent damage to the sensor.



Putting more than 2 Volt across the heater wiring can lead to permanent damage to the heater.



Do not use “open circuit detection” when measuring the sensor output.



If power to the heater is supplied from a 12 VDC source, you must put a 150 Ω resistor in series with the heater.

Contents

Warning statements	2
Contents	3
List of symbols	4
Introduction	5
1 Ordering and checking at delivery	8
1.1 Ordering TP01	8
1.2 Included items	8
1.3 Quick instrument check	8
2 Instrument principle and theory	9
2.1 General theory	9
2.2 Thermal conductivity measurement	10
2.3 Soil thermal conductivity for several soil types	11
2.4 Thermal diffusivity measurement	11
2.5 Volumic heat capacity measurement	12
2.6 Measuring the storage term in soil heat flux measurement	12
2.7 Trend monitoring of soil water content	13
2.8 Calibration	13
2.9 Programming	14
3 Specifications of TP01	16
3.1 Dimensions of TP01	19
4 Standards and recommended practices for use	20
5 Installation of TP01	21
5.1 Site selection and installation	21
5.2 Electrical connection	22
5.3 Requirements for data acquisition / amplification	24
6 Making a dependable measurement	25
6.1 Uncertainty evaluation	25
6.2 Typical measurement uncertainties	25
6.3 Contributions to the uncertainty budget	26
7 Maintenance and trouble shooting	28
7.1 Recommended maintenance and quality assurance	28
7.2 Trouble shooting	29
7.3 TP01 calibration	30
8 Appendices	31
8.1 Appendix on cable extension / replacement	31
8.2 Appendix on preparation of agar gel for calibration	31
8.3 Appendix on use of TP01 beyond its rated measurement range	32
8.4 EU declaration of conformity	33

List of symbols

Quantities

	Symbol	Unit
Thermal conductivity	λ	W/(m·K)
Voltage output	U	V
Voltage output as a function of heating time	U (t)	V
Voltage output difference	ΔU	V
Sensitivity	S	V/K
Heating power per meter	Q	W/m
Heater length	L	m
Temperature	T	°C
Temperature difference	ΔT	°C, K
Time constant	τ	s
Time	t	s
Volumic heat capacity	C_{volumic}	J/(m ³ ·K)
Resistance	R	Ω
Storage term	S	W/m ²
Depth of installation	x	m
Water content (on mass basis)	θ_m	kg/kg
Water content (on volume basis)	θ_v	m ³ /m ³

Subscripts

property of thermopile sensor	sensor
property obtained under calibration reference conditions	reference
property at the (soil) surface	surface
property of the surrounding soil	soil
property of the heater	heater

Introduction

TP01 is a sensor for long-term monitoring of soil thermal conductivity. A measurement with TP01 may also be used to estimate the soil thermal diffusivity and volumic heat capacity, leading to a better understanding of dynamic (variable heat flux) thermal behaviour of soils. TP01 is designed for long-term use at one measurement location. Applied in meteorological surface flux measurement systems, TP01 improves the estimates of soil heat flux and of the so-called storage term (see the paragraph about the storage term). The sensor, combining a heater and a temperature-difference sensor with a high sensitivity and an extremely low thermal mass, is a proprietary Hukseflux design.

The sensor inside TP01 is a temperature-difference sensor consisting of 2 thermopiles. It measures the radial temperature difference around a heating wire with a record breaking sensitivity. Both the heating wire and the sensor are incorporated in a very thin plastic foil.

TP01 measures soil thermal conductivity. It is designed for long-term on-site operation, buried in the soil. Its rated operating range is 0.3 to 4 W/(m·K), which covers most inorganic soil types. The low thermal mass of TP01 also makes it suitable for measuring the soil thermal diffusivity and the volumic heat capacity.

The thermal conductivity, λ , in W/(m·K), is calculated by dividing the TP01 sensitivity, S , by the sensor output, a small voltage difference ΔU which is a response to stepwise heating, and multiplying by the applied electrical power Q per meter heating wire.

The measurement function of TP01 is:

$$\lambda = S \cdot Q / \Delta U \quad (\text{Formula 0.1})$$

The factory-determined sensitivity S , as obtained under calibration reference conditions, is provided with TP01 on its product certificate. TP01 calibration is traceable to international standards. The recommended calibration interval of TP01 is 2 years. Thermal diffusivity and volumic heat capacity are estimated from time response to stepwise heating. These measurements are optional.

The volumic heat capacity is a linear function of soil water content and you may use TP01 measurements to monitor trends in soil water content. Contrary to many other soil water content sensors, TP01 is not sensitive to contamination by salts and the measurement still functions in electrically conducting saline or fertilised soils.

TP01 should be incorporated in the user's measurement and control system. It can be connected directly to commonly used data logging systems. Typically every 6 hours, the TP01 heater is switched on to perform a measurement.

A typical TP01 is part of a meteorological surface flux measurement system in which also wind, humidity, soil heat flux, soil temperatures at different depths and net-radiation are

measured. TP01 then serves to improve the estimate of the so-called storage term, which is used to model thermal heat transport in the soil. Measurements with TP01 are often combined with soil temperature profile measurements with sensor model STP01 and measurements with heat flux sensor model HFP01SC.

Soil thermal properties change as a function of depth, in particular close to the soil surface. A typical measurement location is equipped with sensors at several depths. For good spatial averaging at least 2 sensors (> 5 m apart) should be installed at every depth.

Hukseflux has equipped several testbeds in the electrical power industry, to monitor dryout, thermal runaway and thermal stability around mock-up high-voltage power lines. Here the capability to perform a measurement of thermal diffusivity is an important feature for modelling behaviour under dynamic loads.

Equipped with heavy duty cabling, and potted so that moisture does not penetrate the sensor, TP01 has proven to be very robust and stable. It survives long-term installation in soils.

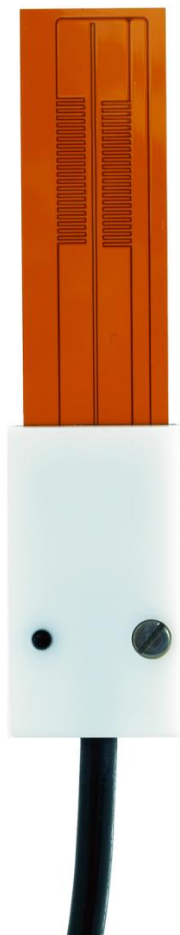

Figure 0.1 TP01. Standard cable length is 5 m.

See also:

- **STP01** soil temperature profile sensor
- for laboratory use, models **TP02** and **TP08** are available. Turn key measuring systems are **TPSYS02**, **FTN02** and **MTN02**.
- Hukseflux **sensors** for surface flux measurement
- heat flux sensors **HFP01** and **HFP01SC**

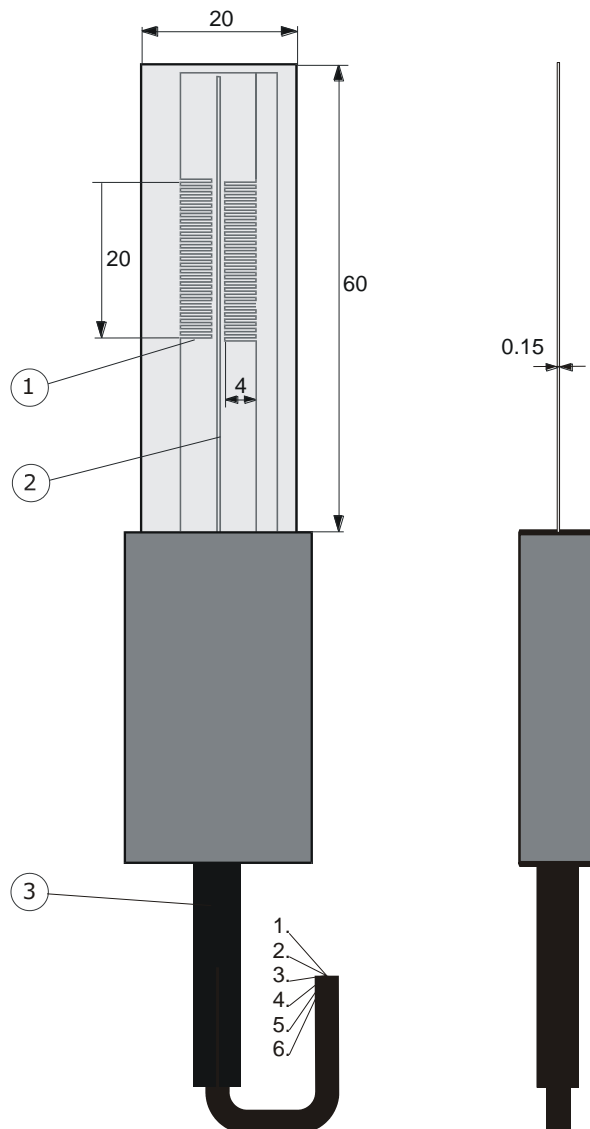

Figure 0.2 TP01 thermal properties sensor. The thermopile sensor (1) and heating wire (2) are both incorporated in a thin plastic foil. The cable (3) is 5 m long in the standard configuration and may be extended to 50 m.

1 Ordering and checking at delivery

1.1 Ordering TP01

The standard configuration of TP01 is with 5 metres cable.

Common options are:

- longer cable in multiples of 5 m, cable lengths above 20 m in multiples of 10 m. specify total cable length.

1.2 Included items

Arriving at the customer, the delivery should include:

- thermal properties sensor TP01
- cable of the length as ordered
- product certificate matching the instrument serial number

1.3 Quick instrument check

A quick test of the instrument can be done by connecting it to a multimeter.

1. Check the electrical resistance of the sensor and heater according to table 5.2.2. Use a multimeter at the 100 Ω range. The typical resistance of the wiring is 0.1 Ω /m (added value of 2 wires). Infinite resistance indicates a broken circuit; zero or a lower than 1 Ω resistance indicates a short circuit.
2. Check if the sensor reacts to heat: put the multimeter at its most sensitive range of DC voltage measurement, typically the 100 $\times 10^{-3}$ VDC range or lower. Activate the TP01 heater by putting 1 to 2 VDC across the brown and yellow wires. Use a 1.5 V battery. Put the sensor in soil or another granular material. The signal between the green and white output should read $> 1 \times 10^{-3}$ V now. It will vary if the sensor moves.
3. Inspect the instrument for any damage.
4. Check the sensor serial number, and sensitivity on the cable labels (one at sensor end, one at cable end) against the product certificate provided with the sensor.

2 Instrument principle and theory

TP01 measures the thermal conductivity [λ] of the surrounding environment. It has a rated measurement range of 0.3 to 5 W/(m·K) which makes it suitable for use in most soils. A requirement for an accurate measurement is that there is good thermal contact between soil and sensor. You must incorporate TP01 in your own measurement and control system. For thermal conductivity measurement this system should perform 2 x voltage readout, and power supply switching. For thermal diffusivity and volumic heat capacity the sensor response time must be measured.

Advantages of using TP01 are:

- high sensitivity (good signal to noise ratio in low-flux environments, low use of power)
- low thermal mass (allows for a quick measurement and the ability to measure thermal diffusivity and heat capacity)
- robustness, including a strong cable (essential for permanently installed sensors)
- IP protection class: IP67 (essential for outdoor application)
- low electrical resistance (low pickup of electrical noise)

2.1 General theory

The thermopile sensor generates a voltage output, as a reaction to the radial temperature difference around the heating wire. This can be seen in figure 2.1.1. It gives a top view of the sensor and the surrounding soil when heating. The heating wire generates a circular temperature field. After 180 s, the temperature difference around the sensor becomes stable.

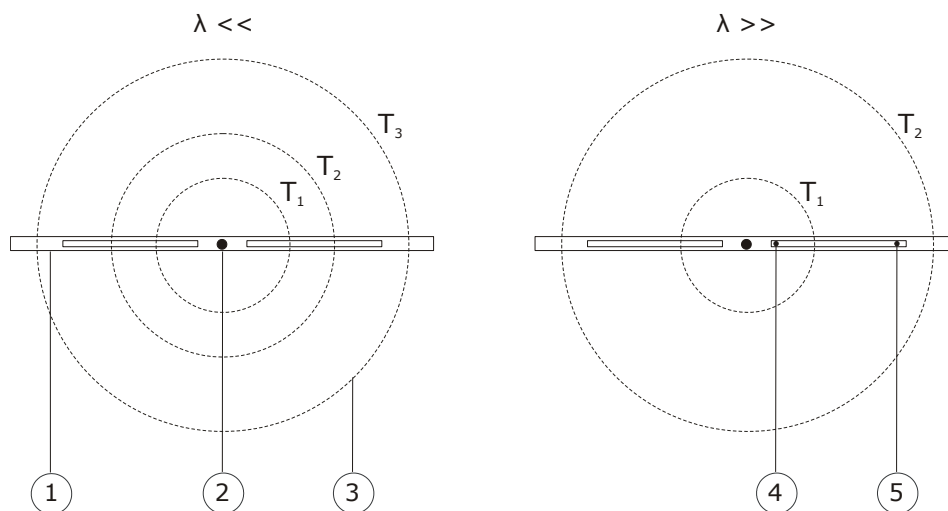

Figure 2.1.1 Top view of the radial temperature distribution (with isotherms (3)) around the heating (2) wire of TP01 (1) in two different environments; right high thermal conductivity, left low thermal conductivity. The thermopiles measure the difference between the temperature at the hot joints (4) and the cold joints (5).

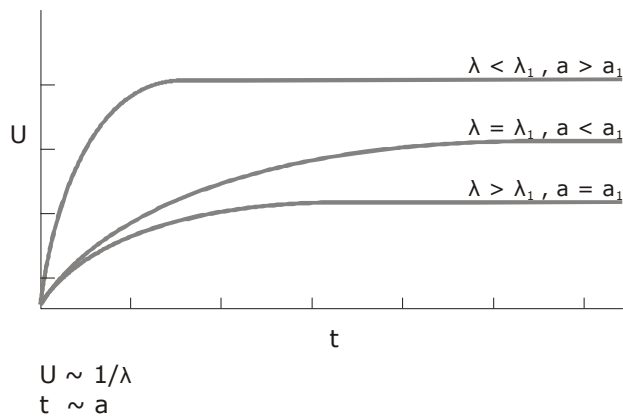

Figure 2.1.2 TP01 signal in different soil types: the signal amplitude varies with $[1/\lambda]$, the response time varies with thermal diffusivity $[a]$

2.2 Thermal conductivity measurement

The measurement principle of TP01 relies on measurement of the radial temperature difference around a heating wire. The temperature difference is measured by two thermopiles connected in series, generating a single output. Both the heater and the thermopile are incorporated in a thin plastic foil.

The thermal conductivity, λ , in $W/(m \cdot K)$, is calculated by dividing the TP01 sensitivity, S , by the output, a small voltage difference ΔU which is a response to stepwise heating, and multiplying by the applied electrical power Q per meter heating wire.

The measurement function of TP01 is:

$$\lambda = S \cdot Q / \Delta U \quad (\text{Formula 0.1})$$

The voltage difference ΔU is determined by performing a measurement just before the heating starts and after heating for 180 s.

$$\Delta U = U(180) - U(0) \quad (\text{Formula 2.2.1})$$

The factory-determined sensitivity S , as obtained under calibration reference conditions, is provided with TP01 on its product certificate. The heating power Q , in W/m , is determined from a voltage measurement across the heater and taking the heater length and electrical resistance into account.

2.3 Soil thermal conductivity for several soil types

Data for the following graph is taken from IEEE standard 442 – IEEE guide for Soil Thermal Resistivity Measurements”, figure 3. It gives orders of magnitude of the thermal conductivity for different soil types as a function of water content.

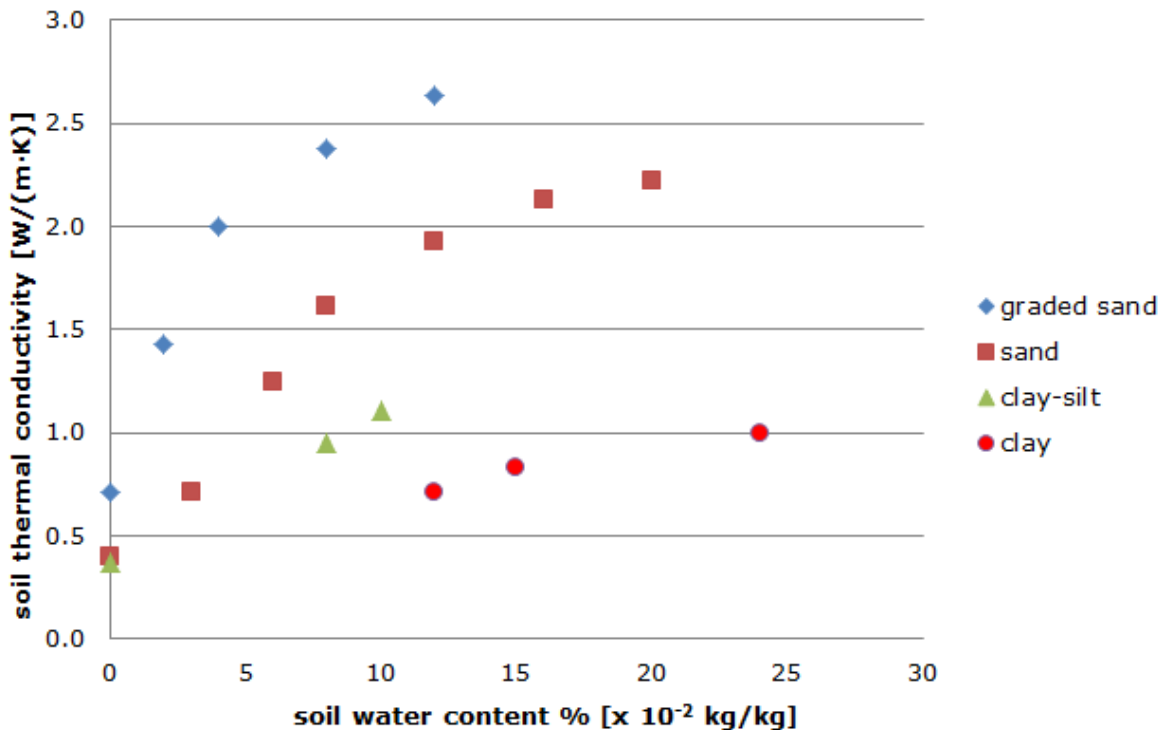

Figure 2.3.1 Typical soil thermal conductivity values for different soil types as a function of water content.

2.4 Thermal diffusivity measurement

The low thermal mass of the total TP01 sensor makes it suitable for estimating thermal diffusivity [a]. Dividing [λ] by the thermal diffusivity [a] gives the volumic heat capacity [C_{volumic}] which varies with water content.

Thermal diffusivity and volumic heat capacity may be estimated from the response time to stepwise heating.

The output response of TP01 to stepwise heating is:

$$\Delta U = (S \cdot Q / \lambda) \cdot F[a \cdot t] \tag{Formula 2.4.1}$$

With [t] time, [a] thermal diffusivity, and F a function that equals 1 at large values of [a·t] and 0 at the start of the heating interval.

Formula 2.4.1 shows that the step response of the sensor signal scales with [Q/ λ] for the amplitude, and with [a] for the time response.

By curve fitting F you can determine $[a]$. One of the easiest ways of doing this is looking at the 63 % response time of the measurement. The common procedure is to first determine the thermal conductivity, and during the settling interval after the heating interval to determine how much time it takes to arrive at 37 % of the ΔU amplitude. The thermal diffusivity is measured by comparing the TP01 response time during the measurement to that under calibration reference conditions. The calibration reference conditions include a thermal diffusivity of $0.14 \cdot 10^{-6} \text{ m}^2 / \text{s}$.

$$a_{\text{reference}} = 0.14 \cdot 10^{-6}$$

The 63 % response time for the determination of the thermal diffusivity is 19 s.

$$T_{\text{reference}} = 19$$

The measurement equation for the thermal diffusivity is:

$$a = a_{\text{reference}} \cdot T_{\text{reference}} / T \quad (\text{Formula 2.4.2})$$

2.5 Volumic heat capacity measurement

The volumic heat capacity is determined from

$$c_{\text{volumic}} = \lambda / a \quad (\text{Formula 2.5.1})$$

2.6 Measuring the storage term in soil heat flux measurement

In meteorological experiments one of the measured parameters is heat flux in the soil. For practical reasons this is done at 0.05 m depth. There is no simple solution for direct measurement of soil heat flux at the soil surface, which is the parameter that must eventually be estimated.

The flux at the soil surface Φ_{surface} is usually estimated from the flux measured by the heat flux sensor buried at a depth of around 0.05 m plus the change of the energy stored in the layer above the sensor during the measuring interval t_1 to t_2 .

$$\Phi_{\text{surface}} = \Phi_{0.05 \text{ m}} + S \quad (\text{Formula 2.6.1})$$

The quantity S is called the storage term.

The storage term is calculated from a space-averaged soil temperature measurement, using multiple soil temperature sensors, and an estimate of the volumic heat capacity c_{volumic} of the soil above the sensor.

$$S = (T(t_1) - T(t_2)) \cdot c_{\text{volumic}} \cdot x / (t_1 - t_2) \quad (\text{Formula 2.6.2})$$

Where $T(t_1) - T(t_2)$ is the temperature difference in the measurement interval, x the depth of installation of the soil heat flux sensors.

A correct estimate of Φ_{surface} with a high time resolution requires a low depth of installation and a correct estimate of the storage term.

At an installation depth of 0.05 m, the storage term typically represents up to 50 % of the total Φ_{surface} . When the temperature T is measured closely below the surface, the response time of the storage term to a changing Φ_{surface} is in the order of magnitude of 20 min, while the heat flux sensor buried at twice the depth is a factor 5 slower (square of the depth). The volumic heat capacity is estimated from the specific heat capacity of dry soil, $c_{\text{soil, dry}}$, the bulk density of the dry soil ρ , the water content on mass basis Q , on a volume basis Q_v , and c_{water} , the specific heat capacity of water.

$$C_{\text{volumic}} = \rho_{\text{soil}} \cdot (c_{\text{soil, dry}} + \theta_m \cdot c_{\text{water}}) = \rho_{\text{soil}} \cdot c_{\text{soil, dry}} + \rho_{\text{water}} \cdot \theta_v \cdot c_{\text{water}} \quad (\text{Formula 2.6.3})$$

The heat capacity of water is known, but the other quantities of the equation are difficult to determine and vary with location and time. The storage term may be the main source of uncertainty in the soil energy balance measurement.

With TP01 the estimate of the volumic heat capacity is much simpler:

$$C_{\text{volumic}} = \lambda/a \quad (\text{Formula 2.5.1})$$

2.7 Trend monitoring of soil water content

In a certain soil type there are direct and linear relationships between the soil water content by mass or volume and the volumic heat capacity. TP01 can therefore be used to monitor trends of soil water content even without detailed knowledge of soil dry densities and heat capacities.

$$\theta_m = ((C_{\text{volumic}} / \rho_{\text{soil}}) - c_{\text{soil, dry}}) / c_{\text{water}} \quad (\text{Formula 2.7.1})$$

For estimates on a volume basis, one has to multiply by ρ_{soil} and divide by ρ_{water} :

$$\theta_v = (C_{\text{volumic}} - c_{\text{soil, dry}} \rho_{\text{soil}}) / \rho_{\text{water}} c_{\text{water}} \quad (\text{Formula 2.7.2})$$

2.8 Calibration

TP01 factory calibration is traceable from SI.

TP01 is calibrated by a thermal conductivity measurement in a calibration reference material, and by performing an electrical resistance measurement.

The test method is not standardised. The calibration reference material is a verified intrinsic measurement standard (vocabulary according to ISO Guide 99), an agar gel, which has thermal properties similar to water. The agar gel is characterised by a reference thermal needle, which is traceable to length and electrical resistance. The TP01 heater electrical resistance is traceable to current and voltage standards.

2.9 Programming

Soil conditions typically change slowly. A typical time between measurements is 6 hr. You may choose to shorten the interval between measurements to 3 hr.

2.9.1 Programming for thermal conductivity measurement

$$\lambda = S \cdot Q / \Delta U \quad (\text{Formula 0.1})$$

The power Q in W/m can be determined from the voltage across the heater U_{heater} and the heater resistance

$$\lambda = S \cdot U_{\text{heater}}^2 / (\Delta U \cdot R \cdot L) \quad (\text{Formula 2.9.1.1})$$

With S the sensitivity, R the heater electrical resistance and L the heater length. These parameters can be found on TP01's calibration certificate. For the standard model TP01, the heater length L is 0.06 m, and the heating time interval is 180 s, so that the measurement equation becomes

$$\lambda = S \cdot U_{\text{heater}}^2 / (0.06 (U(180) - U(0)) \cdot R) \quad (\text{Formula 2.9.1.2})$$

You may define an acceptance interval for λ , and for U_{heater} .

2.9.2 Programming for thermal diffusivity measurement

By curve fitting F you can determine $[a]$. One of the easiest ways of doing this is looking at the 63 % response time of the measurement. The common procedure is to first determine the thermal conductivity, and during the settling interval after the heating interval to determine how much time it takes to arrive at 37 % of the ΔU amplitude.

The measurement equation for the thermal diffusivity is:

$$\begin{aligned} a &= a_{\text{reference}} \cdot T_{\text{reference}} / T && (\text{Formula 2.4.2}) \\ &= (0.14 \times 10^{-6}) \cdot 19 / \tau \\ &= 7.4 \times 10^{-3} / \tau \end{aligned}$$

For a reasonably accurate estimate of the thermal diffusivity, the data storage interval must be < 1 s.

2.9.3 Programming for the volumic heat capacity measurement

$$c_{\text{volumic}} = \lambda / a \quad (\text{Formula 2.5.1})$$

2.9.4 Program summary

In case the user writes his own software program for controlling the TP01, the program flow in table 2.9.4.1 may be used.

Use a < 1 s data storage interval when the thermal diffusivity is measured.

Table 2.9.4.1 A summary of a program for control of the measurement with TP01

initialisation	enter sensor and system information	serial number, S, R, L, $a_{\text{reference}}$, $T_{\text{reference}}$
every 6 h		
	360 s thermal conductivity and thermal diffusivity measurement	measure U, U_{heater} , t
		180 s heating interval
		heater on
		measure U
		measure U_{heater}
		180 s settling interval
		heater off
		measure U
	thermal	calculate λ
		calculate a
	quality checks	acceptance interval λ
		acceptance interval a
		acceptance interval U_{heater}
		Acceptance interval $U(0) - U(180)$
		if accepted, then
		else
		next loop
		generate warning
	calculate derived parameters such as θ	

3 Specifications of TP01

TP01 measures the thermal conductivity [λ] of its surrounding environment. It is designed for long-term monitoring of soils. It has a rated measurement range of 0.3 to 5 W/(m·K) which makes it suitable for use in most (inorganic) soils. It is also used for measurement of thermal diffusivity and volumic heat capacity. Good thermal contact between soil and sensor is required. TP01 can only be used in combination with a suitable measurement and control system.

Table 3.1 Specifications of TP01 (continued on next page)

TP01 SPECIFICATIONS	
Sensor type	thermal properties sensor
Measurand	thermal conductivity
Rated operating environment	surrounded by soil non-organic, saline and non-saline, fertilised and non-fertilised soils
Measurand in SI units	thermal conductivity in W/(m·K)
Measurement range	0.3 to 5 W/(m·K)
Optional non-traceable measurand	thermal diffusivity
Measurand in SI units	thermal diffusivity in m ² /s
Measurement range	(0.05 to 1) × 10 ⁻⁶ m ² /s
Optional non-traceable measurand	volumic heat capacity
Measurand in SI units	volumic heat capacity in J/(kg·K)
Optional trend monitoring	soil water content
Measurand in SI units	water content in kg/kg or m ³ /m ³
Measurement principle	radial temperature difference measurement around a heating wire using a thermopile sensor
Sensitivity	150 × 10 ⁻⁶ V/K (nominal)
Expected voltage output	-1 to 1 × 10 ⁻³ V (thermopile sensor) 0 to 1.5 VDC (heater)
Required programming	measurement of thermal conductivity optionally measurement of thermal diffusivity and volumic heat capacity
Measurement function / required programming	$\lambda = S \cdot Q / \Delta U$
Optional measurement function/ optional programming	$a = a_{\text{reference}} \cdot T_{\text{reference}} / T$
Optional measurement function/ optional programming	$C_{\text{volumic}} = \lambda/a$
Required readout and control	thermopile sensor and heater: 2 x differential voltage channel or 2 x single ended voltage channel, input resistance > 10 ⁶ Ω heater: 1 x switchable power 1 - 2 VDC
Required uncertainty	10 × 10 ⁻⁶ V at 10 ⁻³ V 5 × 10 ⁻³ V at 2 V
Rated operating temperature range	-30 to +80 °C
Temperature dependence	< 0.1 %/°C
Time constant in agar gel calibration reference material	19 s (nominal)
Non-stability	< 1 %/yr

Table 3.1 Specifications of TP01 (started on previous page, continued on next page)

Sensor foil surface dimensions	$(60 \times 20) \times 10^{-3} \text{ m}$
Sensor foil thickness	$0.15 \times 10^{-3} \text{ m}$
Connector block dimensions	$(43 \times 24 \times 10) \times 10^{-3} \text{ m}$
Thermopile sensor number of thermocouple pairs	40
Thermopile sensor resistance range	20 to 50 Ω
Standard governing use of the instrument	not applicable
Standard cable length (see options)	5 m
Wiring	0.15 m wires and shield at cable ends
Cable diameter	$5 \times 10^{-3} \text{ m}$
Cable markers	2 x sticker, 1 x at sensor and 1 x cable end, wrapped around the sensor cable. Both stickers show serial number.
IP protection class	IP67
Rated operating relative humidity range	0 to 100 %
Gross weight including 5 m cable	approx. 0.5 kg
Net weight including 5 m cable	approx. 0.5 kg
HEATER	
Heater resistance (nominal)	15 Ω (measured value supplied with each sensor in the production report)
Heater resistance range	10 to 20 Ω
Heater length	0.06 m
Heater rated power supply	1 to 2 VDC , 0.4 A
Heater power supply	1 VDC (nominal)
Power consumption during heating interval	0.9 W (heater powered from 12 VDC, using a 150 Ω series resistor)
Suggested series resistor when powered from 12 VDC	150 $\Omega \pm 5 \%$, 2 W in series with the heater
Limiting heating power	0.8 W/m
MEASUREMENT	
Power consumption daily average	0.007 W (heater powered from 12 VDC, using a 150 Ω series resistor, at a 6 hr measurement interval)
Interval between measurements	6 hr, optionally 3 or 12 hr
Duration of measurement	360 s
Heating interval duration	180 s
Settling interval duration	180 s
INSTALLATION AND USE	
Measurement depth	0 to 20 m
Recommended number of sensors	at a measurement site, at every required measurement depth use > 2 sensors at a distance of > 5 m
Orientation	recommended orientation is with foil surface vertically oriented (usually this is perpendicular to the soil surface), so that flow of water is not obstructed.
Installation	see recommendations in the product manual
Cable extension	see chapter on cable extension or order sensors with longer cable

Table 3.1 Specifications of TP01 (started on previous pages)

CALIBRATION	
Calibration traceability	to SI units
Production certificate	included (showing calibration result and traceability, as well as heater resistance and heater length)
Factory calibration method	method TPSC
Factory calibration uncertainty	10 % (k = 2)
Recommended recalibration interval	2 years
Factory calibration reference conditions	20 °C, thermal conductivity of the surrounding environment 0.6 W/(m·K)
Validity of calibration	based on experience the instrument sensitivity will not change during storage. During use the instrument “non-stability” specification is applicable.
Calibration reference material	agar gel, which has thermal properties identical to those of water: thermal conductivity of 0.6 W/(m·K) thermal diffusivity of $0.14 \times 10^{-6} \text{ m}^2/\text{s}$ both at 20 °C
MEASUREMENT ACCURACY	
Uncertainty of the measurement	statements about the overall measurement uncertainty can only be made on an individual basis. see the chapter on uncertainty evaluation.
VERSIONS / OPTIONS	
Order code	TP01/cable length in m
Longer cable	in multiples of 5 m, cable lengths above 20 m in multiples of 10 m option code = total cable length
ACCESSORIES	
No accessories	

3.1 Dimensions of TP01

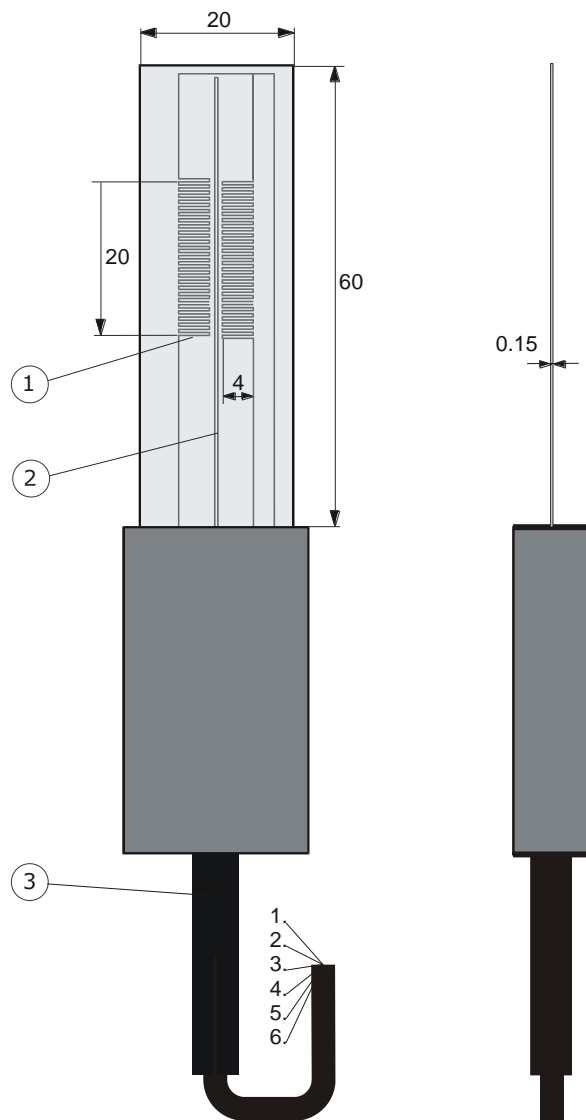

Figure 3.1.1 TP01 thermal properties sensor. dimensions in $\times 10^{-3}$ m.

- (1) thermopile sensor
- (2) heating wire
- (3) cable (standard length 5 m, optionally longer cable in multiples of 5 m, cable above 20 m in multiples of 10 m)

4 Standards and recommended practices for use

TP01 sensors are used to measure heat flux in soils, as part of meteorological surface flux measuring systems. Typically the total measuring system consists of multiple heat flux- and temperature sensors, often combined with measurements of air temperature, humidity, solar- or net radiation and wind speed.

There are no standardised operating practices for use of TP01 sensors. The next chapters contain recommendations of the sensor manufacturer.

In meteorological applications a thermal properties sensor measures thermal conductivity and volumic heat capacity of the soil, typically at several depths.

Usually this measurement is combined with measurements of the soil temperature to estimate the heat flux at the soil surface. Knowing the heat flux at the soil surface, it is possible to "close the balance" and estimate the uncertainty of the measurement of the other (convective and evaporative) fluxes.



Figure 4.1 Typical meteorological surface energy balance measurement system with TP01 installed under the soil.

5 Installation of TP01

5.1 Site selection and installation

Table 5.1.1 *Recommendations for installation of TP01*

Location	Preferably install in a large field which is relatively homogeneous and representative of the area under observation.
Depth	Install at the relevant depths for the measurement. Preferred depths of installation differ for each application. To estimate the storage term for soil surface heat flux estimation, a typical depth of installation is 0.05 m; which is as close to the soil surface as practically attainable.
Orientation	Recommended orientation is with foil surface perpendicular to the soil surface, so that flow of water is not obstructed. The measurement will work independent of orientation.
Performing a representative measurement	At every measurement depth we recommend using > 2 sensors per location at a distance of > 5 m. This redundancy also improves the assessment of the measurement accuracy.
Installation	If possible, install the sensor from the side of a small hole. There should be no air gaps between sensor and soil. Use a shovel to make a vertical slice in the soil. Make a hole in the soil at one side of the slice. Keep the excavated soil intact so that after installing the sensor the original soil structure can be restored. The sensor is installed in the undisturbed face of the excavated hole. Make sure the depth of the hole is close to the required depth of installation so that the sensor connector block and cable can rest upon the bottom of the hole. Measure the depth from the soil surface at the top of the hole. With a knife, make a vertical cut at the required depth of installation, into the undisturbed face of the hole. Insert the sensor foil into the cut. Never run the sensor cable directly to the surface. Bury the sensor cable horizontally over a distance of at least 1 m, to minimise thermal conduction through the lead wire. Put the excavated soil back into its original position after the sensor and cable are installed.
Fixation / strain relief	For mechanical stability and in order to avoid exerting too much force on the sensor foil, provide sensor cables with additional strain relief, for example connecting the cable with a tie wrap to one or more metal pins that are inserted firmly into the soil.
Armoured cable	In some cases cables are equipped with additional armour to avoid damage by rodents. Make sure the armour does not act as a conductor of heat or a transport conduit or container of water.
Added temperature and heat flux sensors	Temperature sensors and heat flux sensors are typically located close to the sensor.

5.2 Electrical connection

A TP01 must be connected to a measurement and control system, typically a so-called datalogger. TP01's thermopile sensor is a passive sensor that does not need any power. The heater is powered from 1 to 2 VDC, using a user-supplied relay to switch it on and off. The 4-wire connection to the heater makes it possible to perform a heater voltage measurement that does not depend on the cable length. Two wires carry the heater current, the others are used for the measurement. No current flows through the latter wires, so that there is no voltage drop, and the true voltage across the heater is measured.



Putting more than 2 Volt across the sensor wiring can lead to permanent damage to the sensor.



Putting more than 2 Volt across the heater wiring can lead to permanent damage to the heater.



If power to the heater is supplied from a 12 VDC source, you must put a 150 Ω resistor in series with the heater.

Cables may act as a source of distortion, by picking up capacitive noise. We recommend keeping the distance between a datalogger or amplifier and the sensor as short as possible. For cable extension, see the appendix on this subject. The thermopile sensor output is connected to a differential or single-ended voltage input.

Table 5.2.1 *Connections of the TP01 cable. The cable internally also has a pink and a grey wire, which are not used and not visible when supplied from the factory. The wires extend 0.15 m from the cable end.*

PIN #	WIRE	FUNCTION	MEASURING SYSTEM
1	White	thermopile signal [+]	analogue voltage [+]
2	Green	thermopile signal [-]	analogue voltage [-] or ground
3	Red	heater voltage output [+]	analogue voltage [+]
4	Brown	heater power supply [+]	heater power supply 1-2 VDC
5	Blue	heater voltage output [-]	analogue voltage [-] or ground
6	Yellow	heater power supply [-]	heater power supply ground w. relay
7	Pink	not connected	not connected
8	Grey	not connected	not connected
9	Black	ground	analog ground

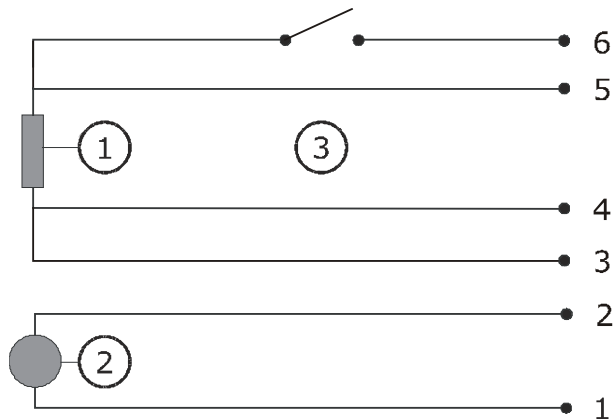

Figure 5.2.1 *Electrical connection of TP01.*

Thermopile sensor (2) wires are connected to datalogger inputs 1 and 2. Heater (1) wires are connected to the power supply at 4 and 6 (with relay). The heater voltage is measured across wires 3 and 5. The relay (not included in the TP01 delivery) is used to switch the heater on and off.

Table 5.2.2 *Resistance checks for diagnostics of TP01*

WIRE #	CLADDING	CLADDING	RESISTANCE ACCEPTANCE INTERVAL
1-2	White	Green	20 to 50 Ω plus 0.1 Ω /m cable resistance
3-4	Red	Brown	0.1 Ω /m cable resistance
3-2	Red	Green	infinite/not connected
3-5	Red	Blue	10 to 20 Ω plus 0.1 Ω /m cable resistance
3-6	Red	Yellow	10 to 20 Ω plus 0.1 Ω /m cable resistance
3-9	Red	Black	infinite/not connected

5.3 Requirements for data acquisition / amplification

The selection and programming of dataloggers is the responsibility of the user. To see if directions for use with TP01 are available: contact the supplier of the data acquisition equipment.

Table 5.3.1 Requirements for data acquisition, amplification and control equipment for TP01 in the standard configuration

Capability to measure small voltage signals	preferably: 10×10^{-6} V uncertainty minimum requirement: 20×10^{-6} V uncertainty (valid for the entire expected temperature range of the acquisition / amplification equipment) Input resistance $> 10^6 \Omega$
Capability to measure the heater voltage	the heater is powered from 2 VDC preferably: 5×10^{-3} V uncertainty minimum requirement: 20×10^{-3} V uncertainty Input resistance $> 10^6 \Omega$
Capability to switch the heater on and off	a relay must be used. In case you are working from 12 VDC, you must install a 150Ω series resistor and the relay must be capable of switching the required 12 VDC at 0.07 A (nominal values).
Capability for the data logger or the software	to store data, and to perform division by the sensitivity to calculate the thermal conductivity. $\lambda = S \cdot Q / \Delta U$ (Equation 0.1) to time and control the measurement to perform comparison of measurement results against the acceptance limits optionally to determine the response time for measurement of the thermal diffusivity and volumic heat capacity using a < 1 s data storage interval. $a = a_{\text{reference}} \cdot T_{\text{reference}} / T$ (Formula 2.4.2) and $C_{\text{volumic}} = \lambda / a$ (Formula 2.5.1)
Open circuit detection (WARNING)	open-circuit detection should not be used, unless this is done separately from the normal measurement by more than 5 times the sensor response time and with a small current only. Thermopile sensors are sensitive to the current that is used during open circuit detection. The current will generate heat, which is measured and will appear as a temporary offset.

6 Making a dependable measurement

6.1 Uncertainty evaluation

A measurement is called “dependable” if it is reliable, i.e. measuring within required uncertainty limits for most of the time and if problems, once they occur, can be solved quickly.

The measurement uncertainty is a function of:

- calibration uncertainty
- differences between reference conditions during calibration and measurement conditions, for example uncertainty caused temperature dependence of the sensitivity
- the duration of sensor employment (involving the non-stability)
- application errors: the measurement conditions and environment in relation to the sensor properties, the influence of the sensor on the measurand, the representativeness of the measurement location
- corrections applied

It is not possible to give a single estimate for TP01 measurement uncertainty. Statements about the overall measurement uncertainty can only be made on an individual basis, taking all these factors into account.

6.2 Typical measurement uncertainties

Table 6.2.1 *Typical measurement uncertainties when measuring with TP01*

APPLICATION	TYPICAL MEASUREMENT UNCERTAINTY BUDGET (K=2)
Meteorology	measurements of soil thermal conductivity may attain uncertainties in the order of $\pm 10\%$ in the rated measurement range of 0.3 to 5 W/(m·K).
	measurements of soil thermal diffusivity may attain uncertainties in the $\pm 20\%$ range in the rated measurement range of 0.3 to 5 W/(m·K)

6.3 Contributions to the uncertainty budget

6.3.1 Non- representativeness of the measurement location.

The representativeness of the measurement location may be assessed by performing multiple measurements at various locations in the same area.

6.3.2 Calibration uncertainty

The main source of uncertainty for thermal conductivity is the uncertainty of calibration, which is defined as $\pm 10\%$. This uncertainty is mainly due to the limited accuracy that Hukseflux can attain when measuring the thermal conductivity of water (or its thermal equivalent agar gel). If the user is prepared to accept agar gel as an “inherent measurement standard” the uncertainty of calibration is $\pm 5\%$.

6.3.3 Non-stability

TP01’s non-stability specification is $< 1\%/yr$. This means that for every year of operation 1% uncertainty should be added in the uncertainty budget.

6.3.4 Temperature dependence

The temperature dependence of the thermopile is $< 0.1\%/K$. That of the heater is negligible.

6.3.5 Heater resistance and length

R_{heater} is a property of the individual sensor. Its nominal value is 20 to 50 Ω . Its exact value can be found on the calibration certificate. The TP01 heater length is 0.06 m. The uncertainties of resistance and length do not play a role in the measurement uncertainty because when calibrating they are entered as constants and part of one factor: $S/(R \cdot L)$ in the measurement equation (Formula 2.9.1.1).

6.3.6 Bad contact to the soil

Uncertainty caused by bad contact to the soil is hard to quantify. The suggestion is to look for yearly patterns, and in the course of time to narrow down acceptance interval limits of thermal conductivity and diffusivity.

6.3.7 Estimate of the time constant

When estimating the thermal diffusivity, the data storage interval must be sufficiently small so that the time constant of the measurement can be compared to the reference time constant of 19 s.

Although it is possible to attain good results by curve fitting, the easiest approach is to sample and store data at an interval < 1 s so that the time interval is not the main factor determining the measurement uncertainty.

7 Maintenance and trouble shooting

7.1 Recommended maintenance and quality assurance

TP01 measures reliably at a low level of maintenance. Unreliable measurement results are detected by scientific judgement, for example by looking for unreasonably large or small measured values of thermal conductivity and thermal diffusivity. The preferred way to obtain a reliable measurement is a regular critical review of the measured data, preferably checking against other measurements.

Table 7.1.1 *Recommended maintenance of TP01. If possible the data analysis should be done on a daily basis.*

MINIMUM RECOMMENDED HEAT FLUX SENSOR MAINTENANCE			
	INTERVAL	SUBJECT	ACTION
1	1 day	measurement	at least one measurement per day
2	1 week	data analysis	compare measured data to the maximum possible or maximum expected thermal properties and to other measurements for example from nearby stations or redundant instruments. Historical seasonal records can be used as a source for expected values. Look for any patterns and events that deviate from what is normal or expected. Analyse the measurement results. Compare to acceptance intervals. Plot thermal conductivity and diffusivity data against other meteorological measurands, in particular soil water content.
3	6 months	inspection	inspect cable quality, inspect mounting, inspect location of installation look for seasonal patterns in measurement data and results of the self-test
4	2 years	lifetime assessment	judge if the instrument will be reliable for another 2 years, or if it should be replaced
5	5 years	recalibration	recalibration by the sensor manufacturer

7.2 Trouble shooting

Table 7.2.1 *Trouble shooting for TP01*

General	<p>Inspect the quality of mounting / installation. Inspect if the wires are properly attached to the data logger. Check the condition of the cable. Inspect the connection of the shield (typically connected at the datalogger side). Check the datalogger program in particular if the right sensitivity, resistance and heater length are entered. TP01 sensitivity and serial number are marked on its cable, electrical resistance and heater length on the product certificate. Check the sensor serial number, and sensitivity on the cable labels (one at sensor end, one at cable end) against the product certificate provided with the sensor.</p>
The sensor does not give any signal	<p>A quick test of the instrument can be done by connecting it to a multimeter. Check the electrical resistance of the sensor and heater according to table 5.2.2. Use a multimeter at the 100 Ω range. The typical resistance of the wiring is 0.1 Ω/m (added value of 2 wires). Infinite resistance indicates a broken circuit; zero or a lower than 1 Ω resistance indicates a short circuit. Check if the sensor reacts to heat: put the multimeter at its most sensitive range of DC voltage measurement, typically the 100 x 10⁻³ VDC range or lower. Activate the TP01 heater by putting 1 to 2 VDC across the brown and yellow wires. Use a 1.5 V battery. Put the sensor in soil or another granular material. The signal between the green and white output should read > 2 x 10⁻³ V now. It will vary if the sensor moves. Inspect the instrument for any damage. The sensor foil surface should be smooth and have no deep scratches.</p>
The sensor signal is unrealistically high or low	<p>Check the cable condition looking for cable breaks. Check the data acquisition of the sensor measurement by applying a 1 x 10⁻⁶ V source to it in the 1 x 10⁻⁶ V range. Look at the measurement result. Check if it is as expected. Check the data acquisition of the heater voltage measurement by applying a 1 V source to it in. Look at the measurement result. Check if it is as expected. Check the heater voltage output. It should be in the 1 to 2 V range. Check the data acquisition by short circuiting the data acquisition inputs with a 50 Ω resistor. Look at the measured value. Check if the output is close to 0 V.</p>
The sensor signal shows unexpected variations	<p>Check the presence of strong sources of electromagnetic radiation (radar, radio). Check the condition and connection of the shield. Check the condition of the sensor cable. Check if the cable is not moving during the measurement.</p>

7.3 TP01 calibration

Recalibration of TP01's is ideally done by the sensor manufacturer.
The recommended calibration interval of heat flux sensors is 2 years.

If the user is prepared to rely on the thermal properties of agar gel, calibration of TP01 can also be done in any laboratory that has the necessary electronic equipment.

The procedure for calibration is as follows:

- 1) prepare agar gel according to the appendix
- 2) make sure there is perfect contact between the foil of the sensor and the gel.
- 3) mechanically fix the sensor
- 4) perform a calibration by doing a normal measurement in agar gel. Knowing the thermal properties of the gel, S can be calculated and the 63 % response time can be timed.
- 5) measure the heater resistance
- 6) compare to the original production certificate. Within a typical sensor lifetime of 10 years, changes of more than 5 % of S en R_{heater} are unusual.

8 Appendices

8.1 Appendix on cable extension / replacement

TP01 is equipped with one cable. Keep the distance between data logger or amplifier and sensor as short as possible. Cables may act as a source of distortion by picking up capacitive noise. In an electrically “quiet” environment the TP01 cable may be extended without problem to 100 metres. If done properly, the sensor signal, although small, will not significantly degrade because the sensor resistance is very low (which results in good immunity to external sources) and because there is no current flowing (so no resistive losses). Cable and connection specifications are summarised below.

Table 8.1.1 Preferred specifications for cable extension of TP01

Cable	6-wire, shielded, with copper conductor (at Hukseflux 8-wire shielded cable is used, of which only 6 wires are used)
Extension sealing	make sure any connections are sealed against humidity ingress
Conductor resistance	< 0.1 Ω /m
Outer diameter	5 x 10 ⁻³ m
Length	cables should be kept as short as possible, in any case the total cable length should be less than 100 m
Outer mantle	with specifications for outdoor use (for good stability in outdoor applications)
Connection	either solder the new cable conductors and shield to those of the original sensor cable, and make a waterproof connection using heat-shrink tubing with hot-melt adhesive, or use gold plated waterproof connectors. Always connect the shield

8.2 Appendix on preparation of agar gel for calibration

The procedure for calibration of TP01 relies on the use of agar gel. This is a water-based gel, of which the ingredients can be bought in every pharmacy. In most countries agar is also available in food stores that sell environmentally friendly foods. The agar gel is often used for growing bacteria. The agar itself does not significantly influence the thermal properties of water, but reduces the effects of convection.

Prepare agar gel by cooking about 4 grams of agar in 1 litre of water, for about 20 minutes, stirring regularly. The solution is put in a pot, and be allowed to cool down and solidify. This typically takes some hours. Use a pot which may be sealed. Once at room temperature, make a slit in the gel using a knife. Insert the TP01 into the slit. Add some water with a liquid antiseptic such as Dettol to suppress bacterial growth, and promote the thermal contact between the gel and the sensor foil. Make sure the water fully covers the gel in a layer of about 1×10^{-3} m.

We assume by scientific judgement that the properties of agar gel at 4×10^{-3} kg/kg are the same as those of pure water:

Thermal conductivity: 0.6 W/(m·K), at 20 °C
 Thermal diffusivity: 0.14×10^{-6} m² /s

8.3 Appendix on use of TP01 beyond its rated measurement range

The rated measurement range of TP01 is 0.3 to 5 W/(m·K). Use beyond this rated range is possible, but will lead to higher measurement uncertainties. At lower thermal conductivities the thermal transport through the thermopile metal traces leads to non-linear behaviour. At higher thermal conductivities, the output signal reduces. Table 8.3.1 lists some measurement results.

Table 8.3.1 *Measurements results with TP01 using the normal measurement equation. Dry sand (zero moisture content, which will not occur in a real-life situation) and air are beyond the rated measurement range. The sensor behaviour is strongly non-linear. A measurement in agar gel is at calibration reference conditions and by definition has zero deviation.*

		air	dry sand	moist sand	agar gel	saturated sand
theoretical	[W/(m·K)]	0.02	0.19	0.30	0.61	2.22
measured	[W/(m·K)]	0.16	0.29	0.32	0.61	2.11
deviation from ideal	[%]	689	53	8	0	-5

8.4 EU declaration of conformity



We, Hukseflux Thermal Sensors B.V.
Delftechpark 31
2628 XJ Delft
The Netherlands

in accordance with the requirements of the following directive:

2014/30/EU The Electromagnetic Compatibility Directive

hereby declare under our sole responsibility that:

Product model: TP01
Product type: Thermal properties sensor

has been designed to comply and is in conformity with the relevant sections and applicable requirements of the following standards:

Emission: EN 61326-1 (2006)
Immunity: EN 61326-1 (2006)
Emission: EN 61000-3-2 (2006)
Emission: EN 61000-3-3 (1995) + A1 (2001) + A2 (2005)
Report: 08C01340RPT01, 06 January 2009



Eric HOEKSEMA
Director
Delft
September 08, 2015

